

# Op-Amps & 555 Timers

One of the requirements for your 401 project is it must include an integrated circuit (IC). Usually, this is an op-amp, a 555 timer, or a PIC processor.

## Operational Amplifiers (Op-Amps)

Op-amps are really useful devices that can do all sorts of things. With op-amps, you can build

- Comparitors
- Schmitt Triggers
- Half-wave and full-wave rectifiers,
- Envelope detectors
- Amplifiers
- Filters

to name just a few. Op-amps are just darn useful.

The heart of all of these circuits is an op-amp, such as an MCP602. An MCP602 is used in Senior Design I since

- It can operate from a single 5V power supply (range is 3V to 6V)
- It's a rail-to-rail op-amp. If you connect 0V and 5V to power and ground, the output can go all of the way down to 0V and all the way up to 5V (rail-to-rail).
- It's a dual op-amp: you get two op-amps in each IC

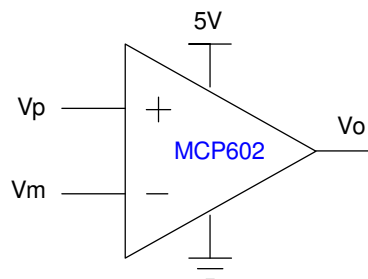
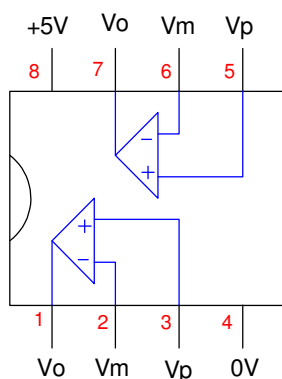

MCP602 op-amp: the heart of a comparitor

Op-amps in general are high-gain differential amplifiers. The MCP602, for example, has an output which is

$$V_o = 200,000(V_p - V_m)$$

where  $V_o$  is clipped at the +5 and 0V power supplies (you can't get more voltage out than you put in).

What this means is

- If  $V_p > V_m$ , the output rails at the upper power supply (5V)
- If  $V_p < V_m$ , the output rails at the lower power supply (0V)

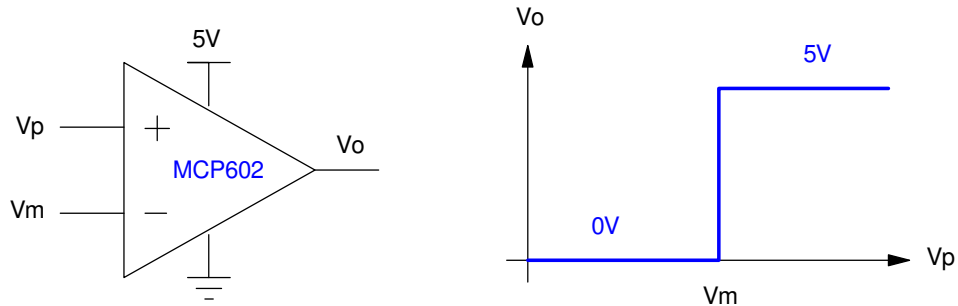

Comparator: Output is 5V if  $V_p > V_m$

This allows you to build several different circuits.

**Comparator:  $Y = (V_{in} > 2.3V)$**

If you want to turn on an LED when  $V_{in} > 2.3V$ , you could use a comparator along with a BJT transistor:

- Connect  $V_{in}$  to  $V_p$
- Connect 2.3V to  $V_m$
- This produces the function:  $Y = V_{in} > 2.3V$

If you swap  $V_p$  and  $V_m$ , you get the opposite ( $V_{in} < 2.3V$ )

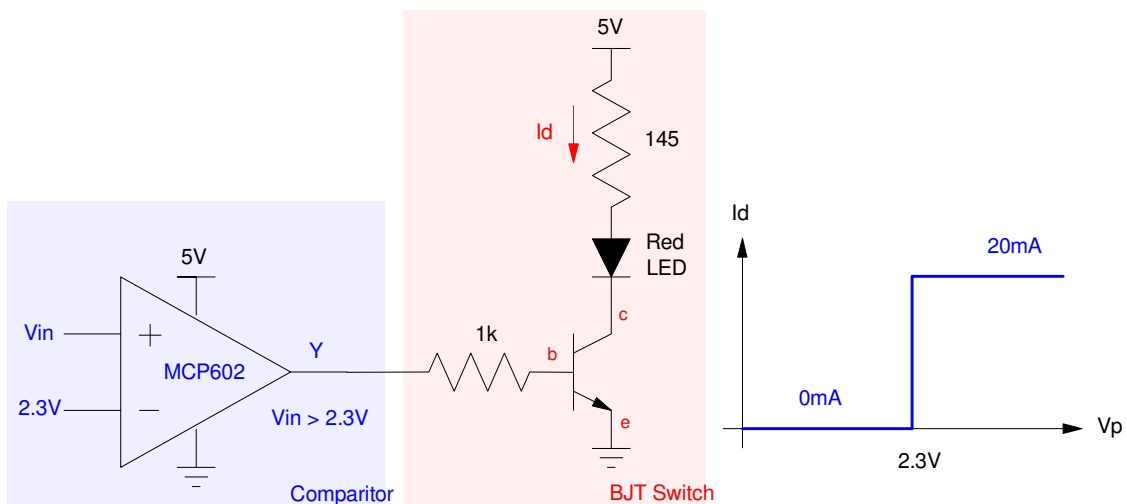

Comparator with a BJT switch. LED is on when  $V_{in} > 2.3V$

**Comparator: Y = (T > 20C)**

If you want to turn on an LED when the temperature is more than 20C,

- First, convert temperature to resistance. A thermistor such as the ones used in ECE 376 will do that

$$R = 1000 \cdot \exp\left(\frac{3905}{T+273} - \frac{3905}{298}\right) \Omega$$

- Next, convert resistance to voltage. A voltage divider will do that
- Connect Vm to the output of the voltage driver.
  - As temperature goes up
  - R goes down
  - Vx goes down
  - Y goes up
- Connect Vp to the voltage you get at 20C

$$T = 20C$$

$$R = 1250.59\Omega$$

$$V_x = \left(\frac{R}{R+1000}\right) 5V = 2.778V$$

The final design of the comparator circuit is as follows.

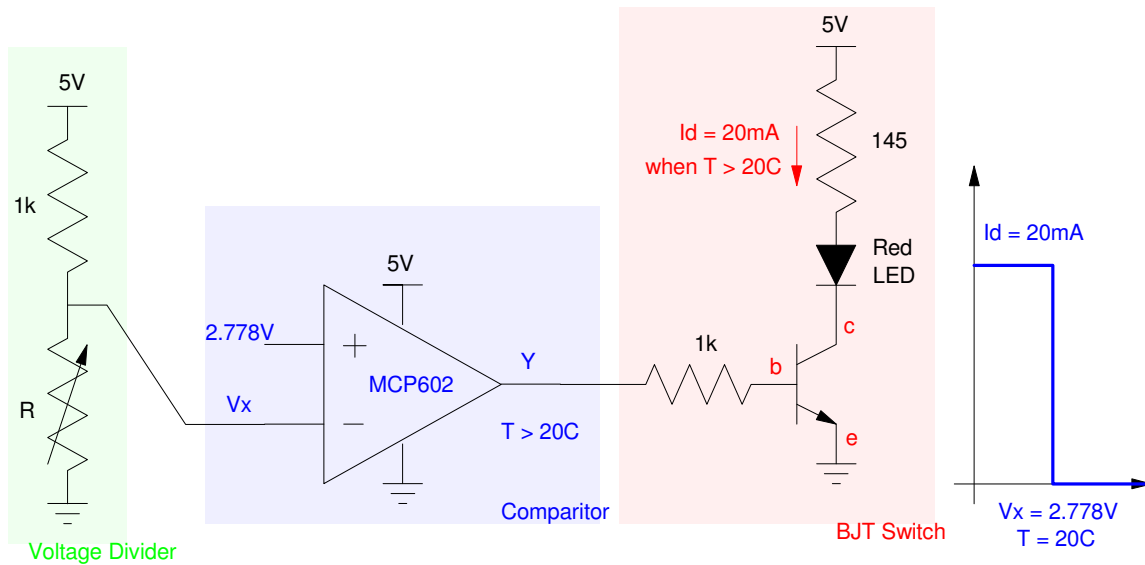

Comparator with a temperature sensor. LED is on when T > 20C

Note

- If you swap Vp and Vm, you get the opposite (light is on when T < 20C).
- If you change R to a light sensor, the LED turns on and off with light level
- If you change R to a magnetic field sensor, the LED turns on and off with magnetic field strength

## Schmitt Triggers

A problem with comparators is they tend to be noisy:

- When  $V_p = V_m$ , the output will chatter between 0V and 5V
- This can cause multiple reads on counters, noise on a speaker, etc.

To prevent this, a Schmitt trigger can be used.

Schmitt Triggers are one of the few circuits you'll ever see which use positive feedback. Positive feedback tends to make things unstable:

- If something is too hot, add more heat
- If the voltage is too high, go higher
- If you're going too fast, go faster

This is intentional with the Schmitt Trigger: you want the output to rail at either +5V or 0V.

With a comparator, the on voltage is the same as the off voltage. With a Schmitt trigger, the two are different. When the on-voltage is more than the off-voltage, the input is connected to the plus input:

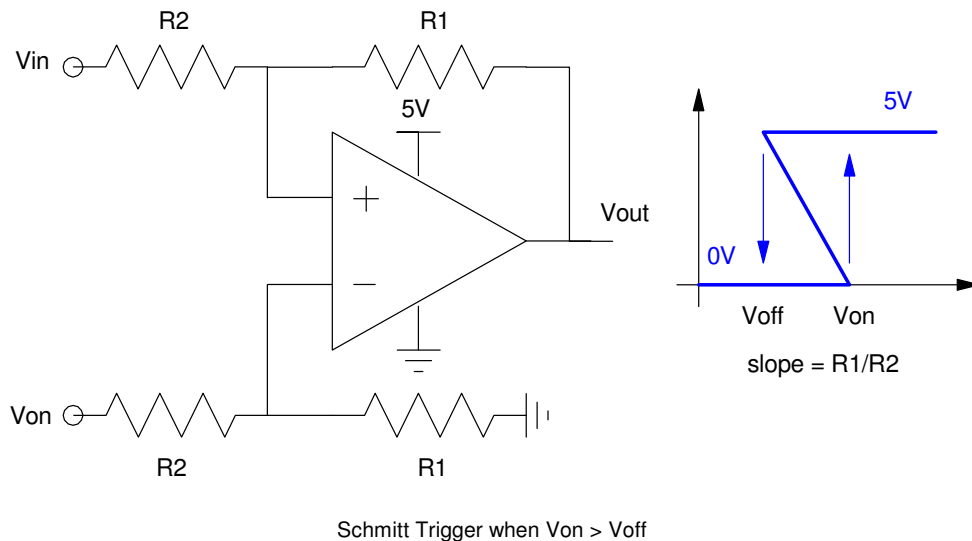

When the on voltage is less than the off voltage,  $V_{in}$  is connected to the minus input:

What the positive feedback does is it changes the on/off voltage when the output switches, creating hysteresis.

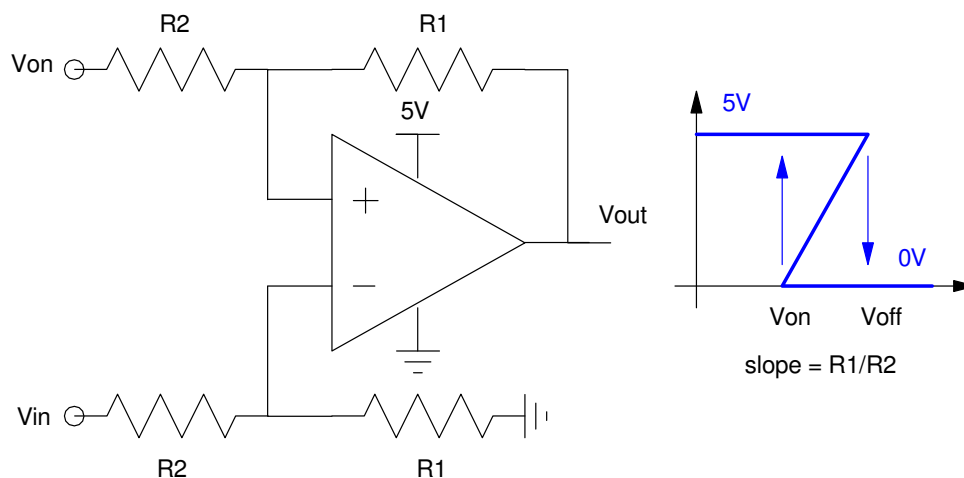

Schmitt Trigger when  $V_{on} < V_{off}$

For example, design a circuit which turns an LED

- On when  $T > 25C$  and
- Off when  $T < 20C$

When  $20V < T < 25C$ , the LED remains unchanged (on or off).

Similar to the comparator, the procedure is to first, convert temperature to a voltage and find  $V_{on}$  and  $V_{off}$ . A voltage divider and a thermistor works for this.

Assuming a thermistor where

$$R = 1000 \exp\left(\frac{3905}{T+273} - \frac{3905}{298}\right) \Omega$$

along with a voltage divider with a 1k resistor, you get

At 20C:

$$R = 1250.59 \Omega$$

$$V_x = \left(\frac{R}{R+1000}\right) 5V = 2.778V$$

$$V_{off} = 2.778V$$

At 25C

$$R = 1000 \Omega$$

$$V_x = 2.500V$$

$$V_{on} = 2.500V$$

Since  $V_{on} < V_{off}$ , connect to the minus input

The gain needed is

$$gain = \left( \frac{\text{change in output}}{\text{change in input}} \right)$$

$$gain = \left( \frac{5V-0V}{2.778V-2.500V} \right) = 17.96$$

A 10k resistor and a 179k resistor works.

The net circuit is then:

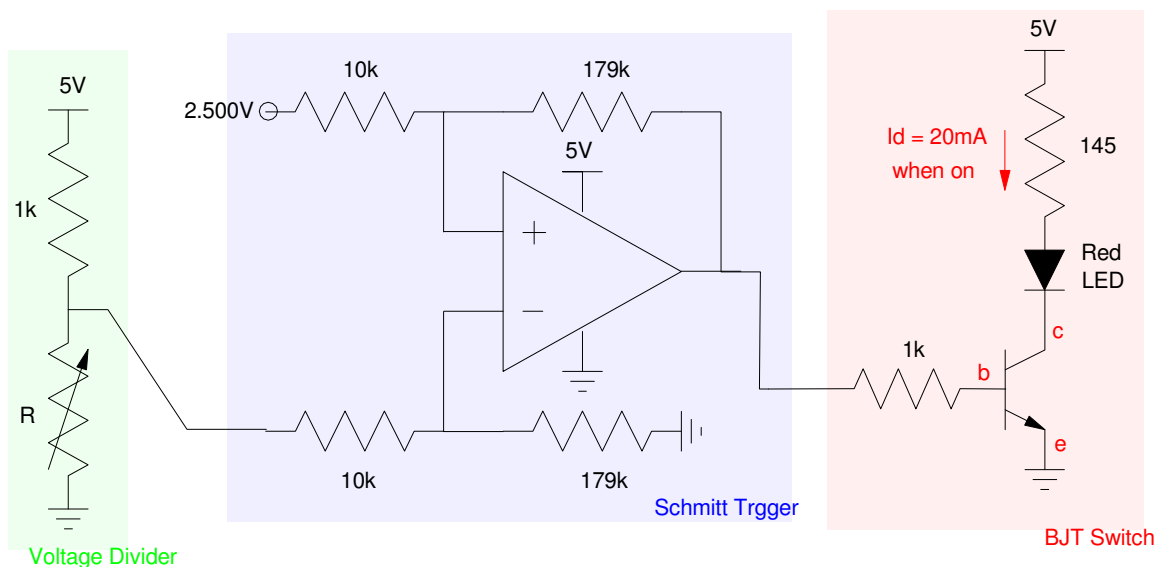

Schmitt Trigger: Diode is turned on at 25C (2.500V) and turned off at 20C (2.778V)

## 555 Timers

Finally, lets look at 555 timers. 555 timers are one of the more useful tools in designing an analog circuits. With it, you can build:

- An oscillator - allowing you to keep track of time, make lights blink, speakers buzz, etc.
- An oscillator whose frequency depends upon temperature, light, water, etc.
- A voltage-controlled oscillator - allowing you to make siren noises, and
- A one-shot - allowing you to do something one time after an event (such as turn on a light for 30 seconds when motion is detected.)

The following circuits are for an oscillator. The other circuits are covered in ECE 320 Electronics I.

### 555 Timer:

555 Timers get their name from the use of three 5k resistors in series. These resistors create two reference voltages equally spaced between ground and the power supply (6V in this example).

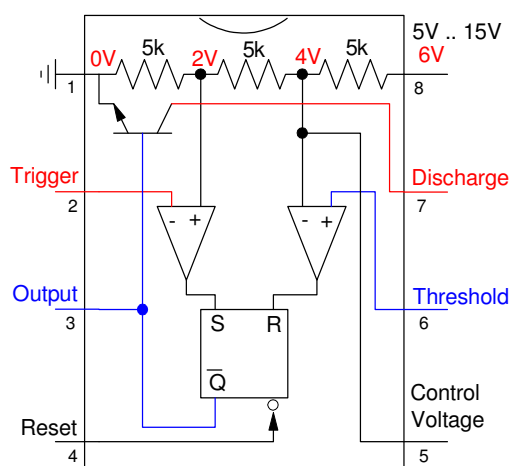

555 Timer Schematic. The 555 refers to three 5k resistors from power to ground.

The function of the pins are as follows (assuming a 6V power supply):

- Power and Ground: self explanatory. Power can be anything from 5V to 15V.
- Trigger: When Trigger < 2V, the SR flip-flop sets and the output goes high.
- Threshold: When Threshold > 4V, the SR flip flop clears and the output goes low
- Control Voltage: Allows you to change the threshold voltage from 4V if you like
- Discharge: When the output is low, Discharge is shorted to ground through a transistor. Otherwise, Discharge is a floating pin.

**555 Oscillator (take 1):** The basic circuit for a 555 oscillator timer is as follows. The way it works is

- The capacitor charges up to 2/3 of 5V through R1 and R2. Once it reaches 3.333V
- Pin 7 is tied to ground, resulting in the capacitor discharging down to 1/3 of 5V through R2. Once V2 reaches 1.667V,
- Pin 7 is turned off, allowing the capacitor to charge back up again,
- And the process repeats.

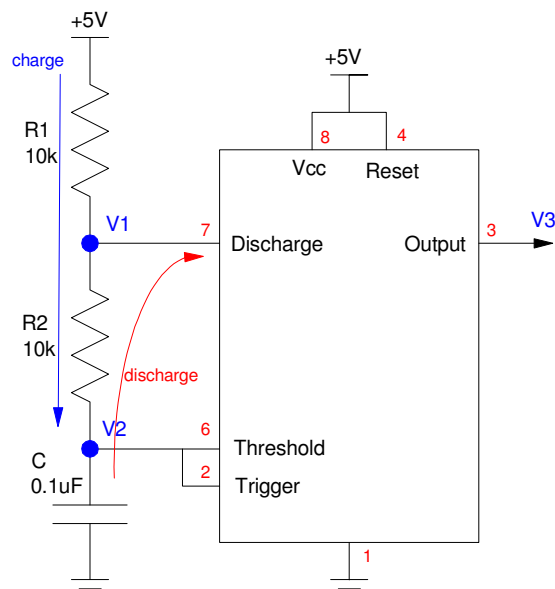

555 Timer in CircuitLab.  
C1 charges through R1 and R2. It discharges through R2

This shows up on the voltages you see at V2 and V3:

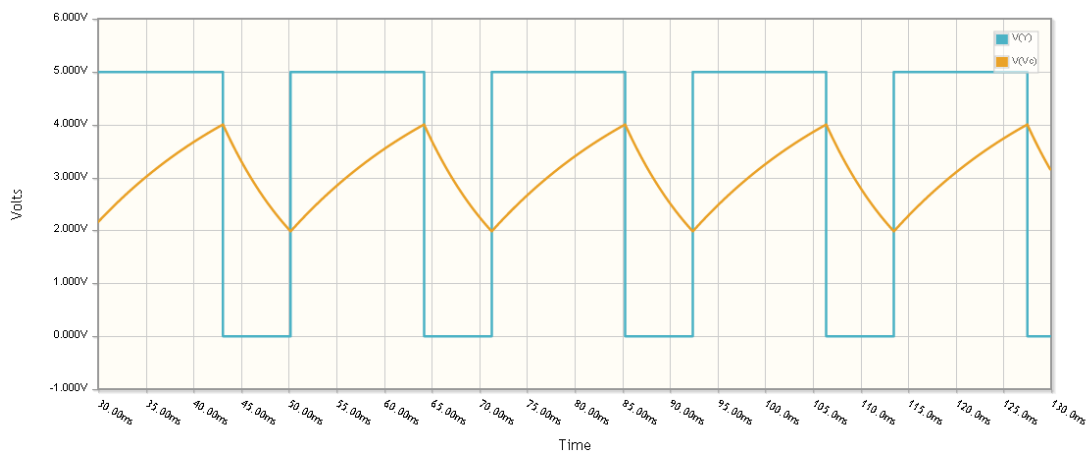

Voltage at Vc (orange) and Y (output = blue)



The on and off times for V3 are set by R1, R2, and C as:

$$T_{on} = (R_1 + R_2) \cdot C \cdot \ln(2)$$

$$T_{off} = R_2 \cdot C \cdot \ln(2)$$

$$T = \text{Period} = T_{on} + T_{off} = (R_1 + 2R_2) \cdot C \cdot \ln(2)$$

For the values given, this works out to

$$T_{on} = 1.386ms$$

$$T_{off} = 0.693ms$$

$$T = \text{Period} = 2.079ms$$

$$f = \frac{1}{T} = 480.9Hz$$

Note

- The on time is twice as large as the off time. This is due to C charging through R1 and R2, while discharging through R2.
- If you replace either resistor with a thermistor or a photo-resistor, the period (and frequency) will change with temperature or light.

**555 Oscillator (take 1):** A slight improvement is to add a diode as follows. This results in

- C charging through R1 (R2 is bypassed by the diode), and
- C discharging through R2 (when pin 7 of the 555 timer is grounded).

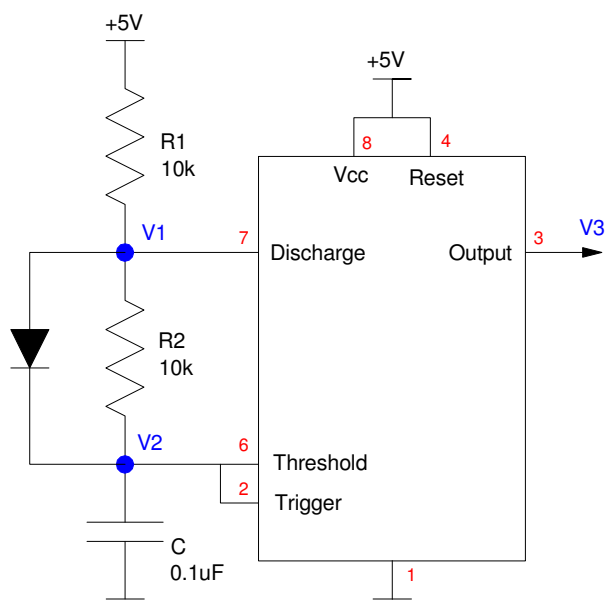

Improved 555 Oscillator. R1 sets the on-time (charging C) and R2 sets the off time (discharge C)

This results in

$$T_{on} \approx R_1 \cdot C \cdot \ln(2)$$

$$T_{off} \approx R_2 \cdot C \cdot \ln(2)$$

(Ton is approximate due to ignoring the voltage drop across the diode when computing Ton).

By adjusting R1 and R2, you can set the on and off times to anything you like. For example, if they're both 10k resistors,

$$T_{on} \approx 0.693ms$$

$$T_{off} \approx 0.693ms$$

$$T = T_{on} + T_{off} = 1.386ms$$

$$f = \frac{1}{T} = 721.3Hz$$

### LED Brightness Control

By varying R1 and R2, you can adjust the on and off times for a 555 timer. An easy way to do this is to use a potentiometer for R1 and R2:

- When the pot is at the top, the on time is zero and the off time is 1.38ms (0% duty cycle)
- When the pot is at the bottom, the on time is 1.38ms and the off time is zero (100% duty cycle)

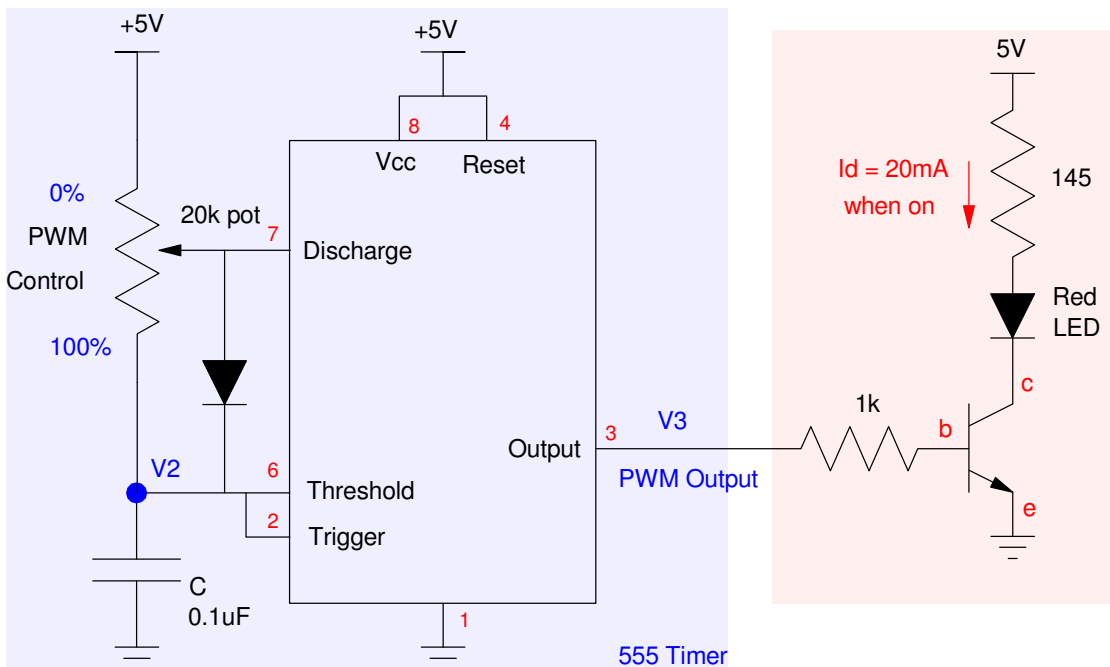

Brightness Control using a 555 Time

### PIC18F2620 Schematics

Finally, several Design I projects use a PIC microcontroller similar to the one used in ECE 376 Embedded Systems.

Microcontrollers are really useful as well. With them, you can

- Read inputs (buttons or voltages),
- Drive outputs (LEDs, buzzers, etc)
- All controlled by software.

If someone in your group is taking or has taken ECE 376, incorporating a PIC microcontroller into your design can simplify the design quite a bit.

The schematics for the bare minimum are as follows:

