Audio and Strain Sensors

ECE 321: Electronics II

Lecture #5

Please visit [Bison Academy](#) for corresponding lecture notes, homework sets, and solutions

Microphones:

There are many types of microphones.

- Some are essentially speakers. From duality, they also produce voltage if you hit them with sound.
- Some are piezo crystals. When you apply a voltage to a piece of quartz, it gets slightly larger. From duality, if you squeeze a piece of quartz (say, with a sound wave), it produces a voltage.
- Some are strain gauges on a membrane. As sound waves hit the membrane, it moves, producing stress and strain on the membrane.

Most of the microphones in lab are Electret Condenser Microphones:

Product Index > Audio Products > Microphones > CUI Inc. CMA-4544PF-W [Add To Favorites](#) ☆ [Share](#)



Product Overview		All prices are in USD.		
Price Break	Unit Price	Extended Price		
1	0.70000	\$0.70		
10	0.55300	\$5.53		
25	0.50240	\$12.56		
50	0.47000	\$23.50		
100	0.43750	\$43.75		

Digi-Key Part Number 102-1721-ND

Quantity Available 72,664
Can ship immediately

Manufacturer [CUI Inc.](#)

Manufacturer Part Number CMA-4544PF-W

To wire up this microphone, a pull-up resistor is used as per the data sheets:
The output signal will be a small (10mV?) audio signal on top of a large DC offset.

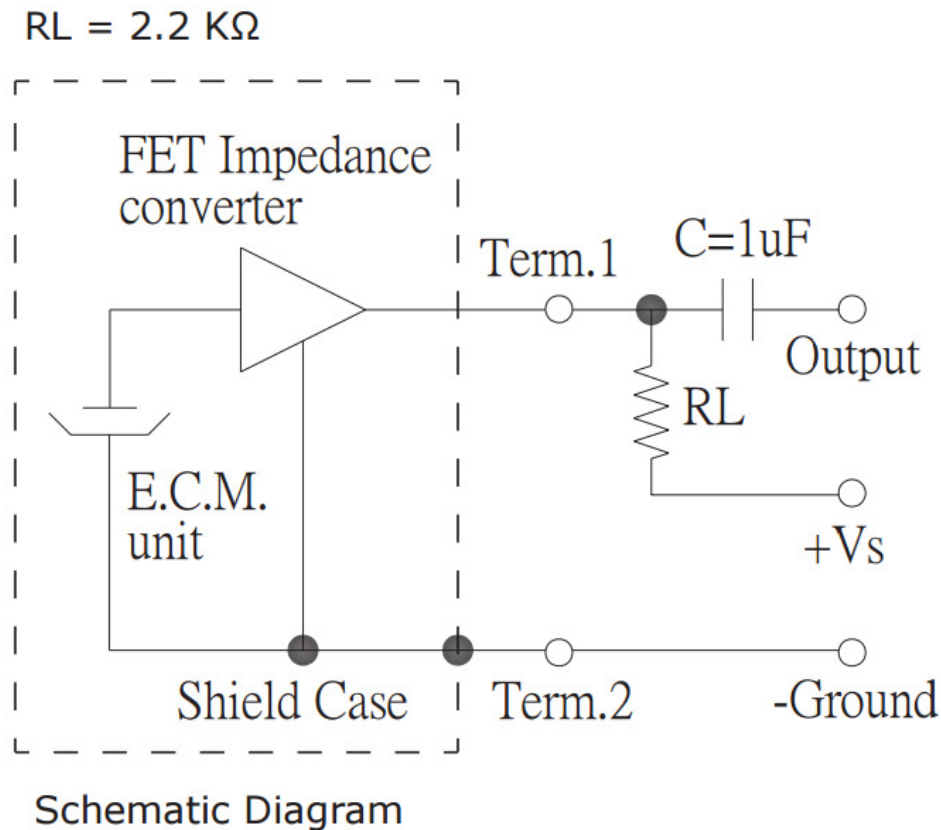

To amplify the signal,

- A DC block is used along with an amplifier
- (note: a speaker can also be used instead of a microphone)

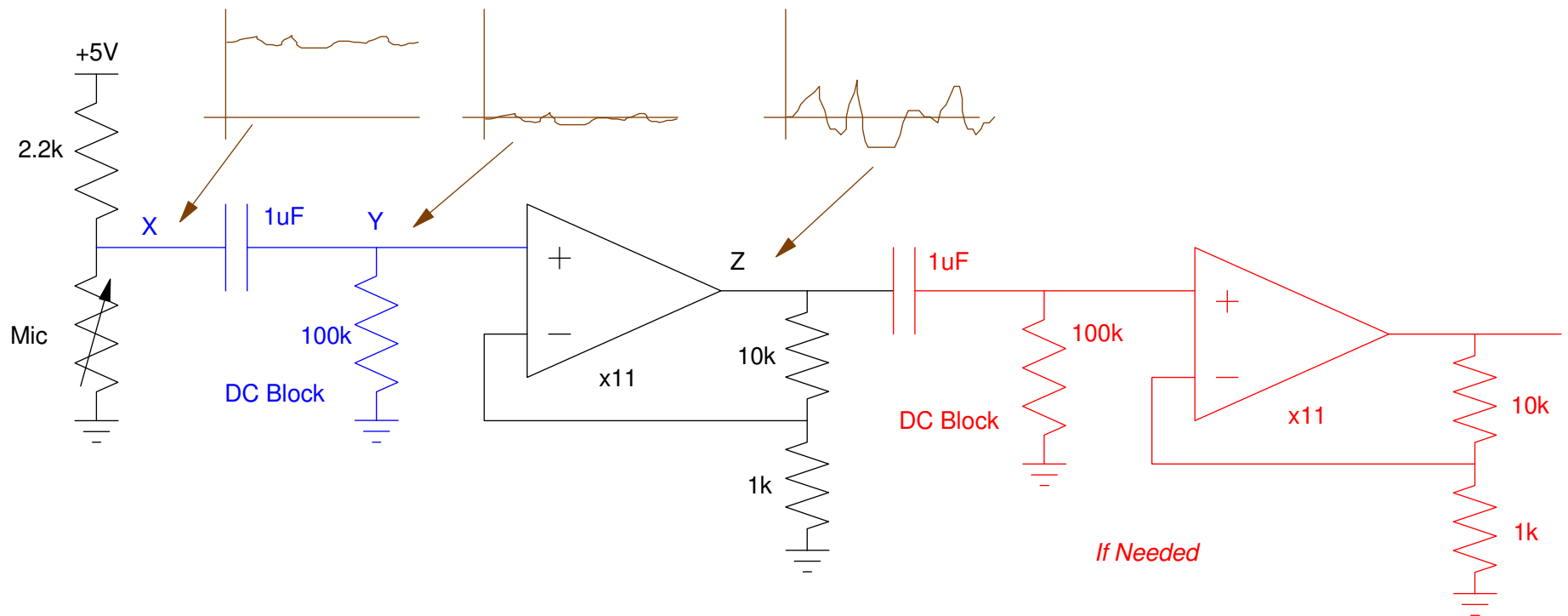

Sound on a Light Beam

Once amplified, you can transmit the sound on a light beam.

- Bias and LED so that $I_d = 10\text{mA}$ (Q-point, DC offset)
- Inject an AC signal on top of the 10mA (DC) signal
- Detect the light beam using a light sensor (LDR).

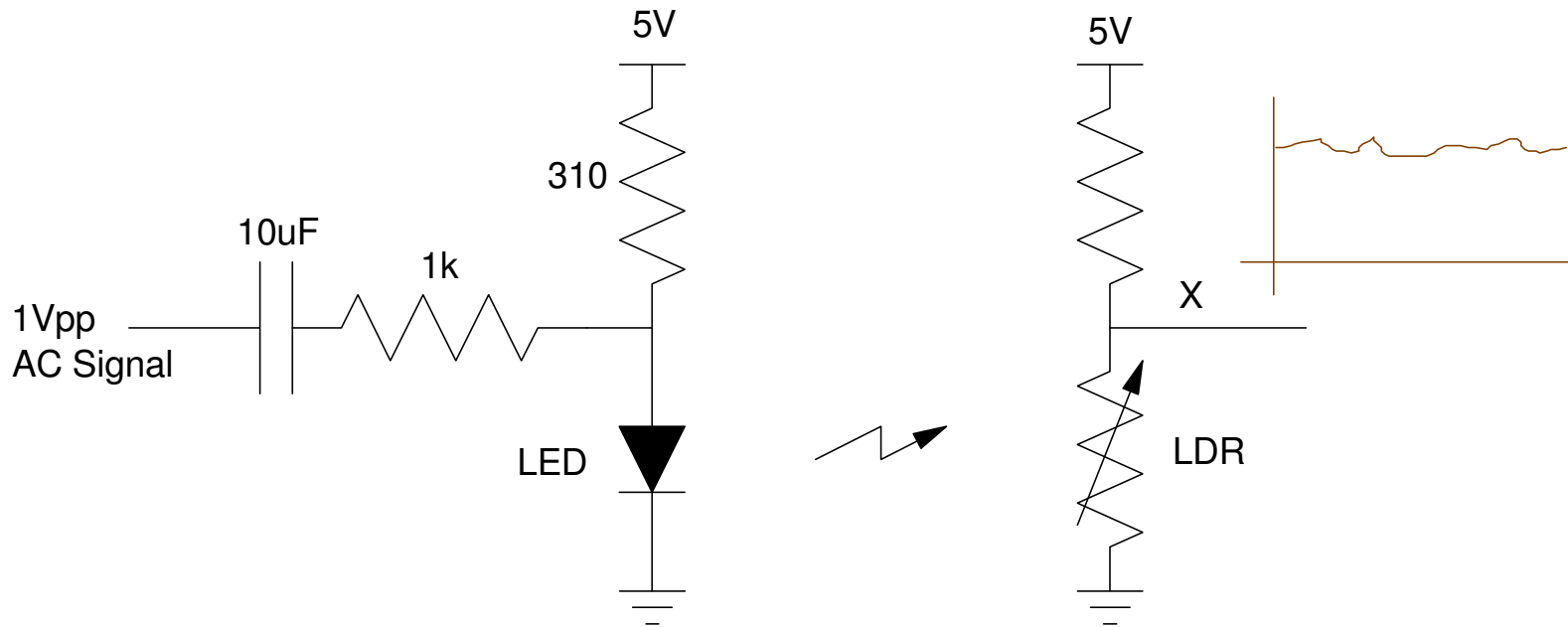

1/2 Wave Rectifier

A diode can be used for a 1/2 wave rectifier, but you lose 0.7V across the diode. With an op-amp, you can remove that 0.7V drop:

If $X > 0$

- $V_+ = V_-$
- $I > 0$
- The diode turns on

If $X < 0$

- The op-amp tries to make $V_+ = V_-$
- Which results in $I < 0$
- Which turns off the diode.

With the diode off, $Y = 0$

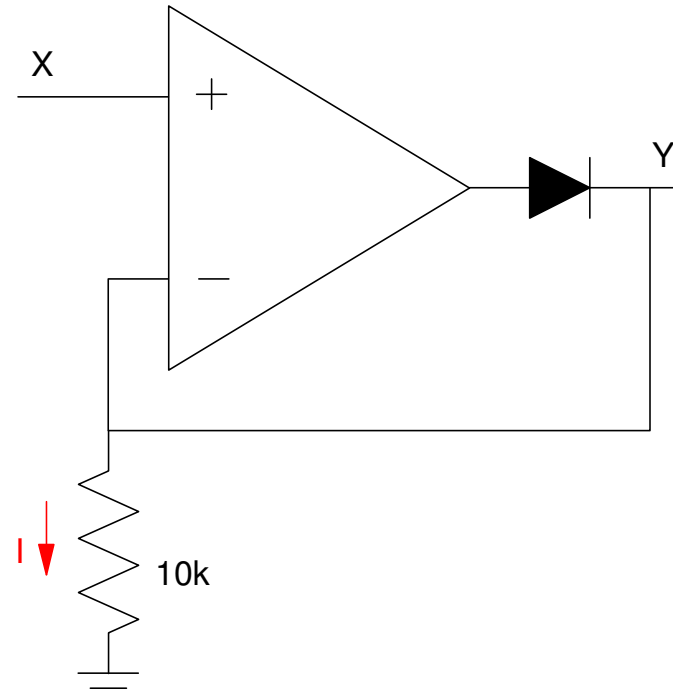

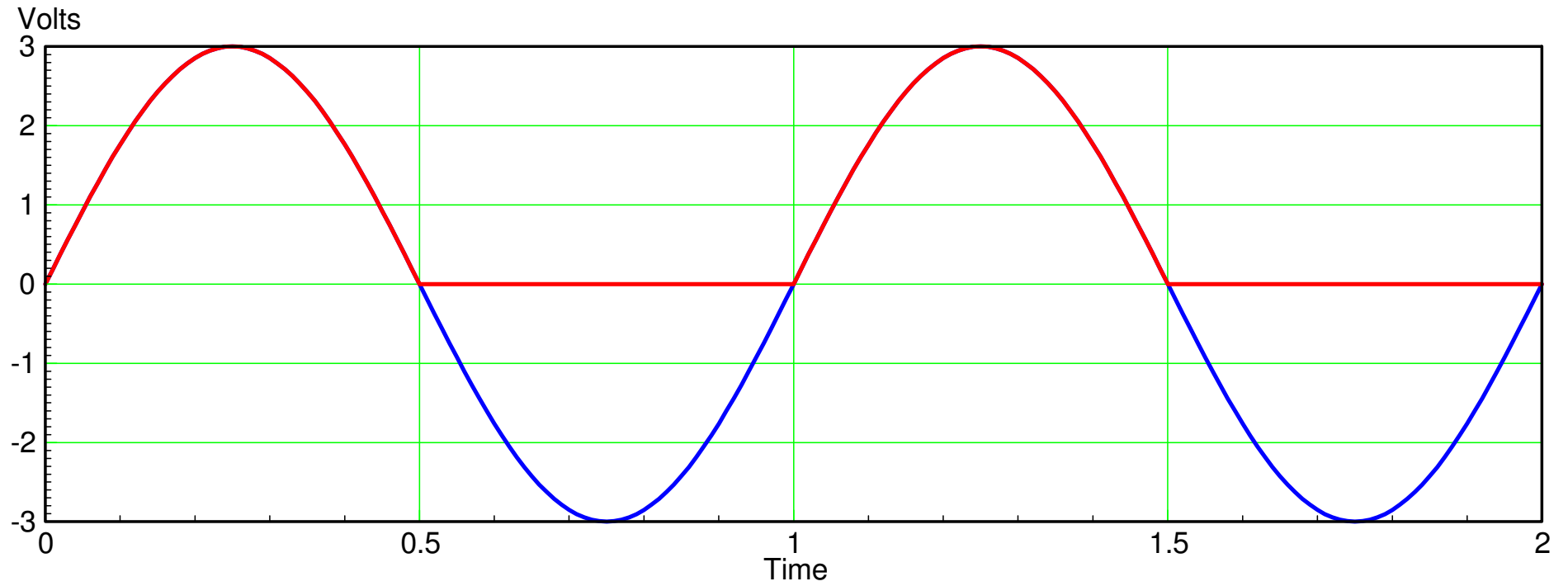

Input (blue) and output (red) for a 1/2 wave rectifier

Envelope Detector: If you add a capacitor across the 10k resistor

- When $X > Y$, the diode turns on, current flows, and the op-amp forces V_+ to equal V_- ($Y=X$)
- When $X < Y$, the diode turns off and the output floats. Y is then the voltage across C , slowly discharging.

The RC time constant tells you how long you hold the voltage at Y :

$$V_y = \alpha \cdot \exp\left(\frac{-t}{RC}\right)$$

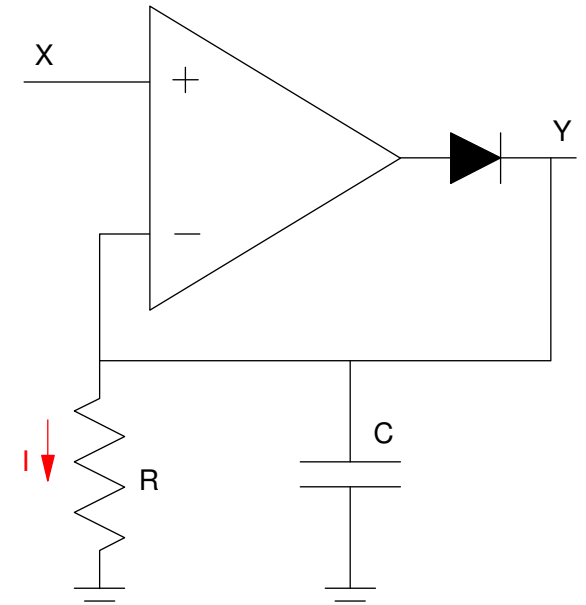

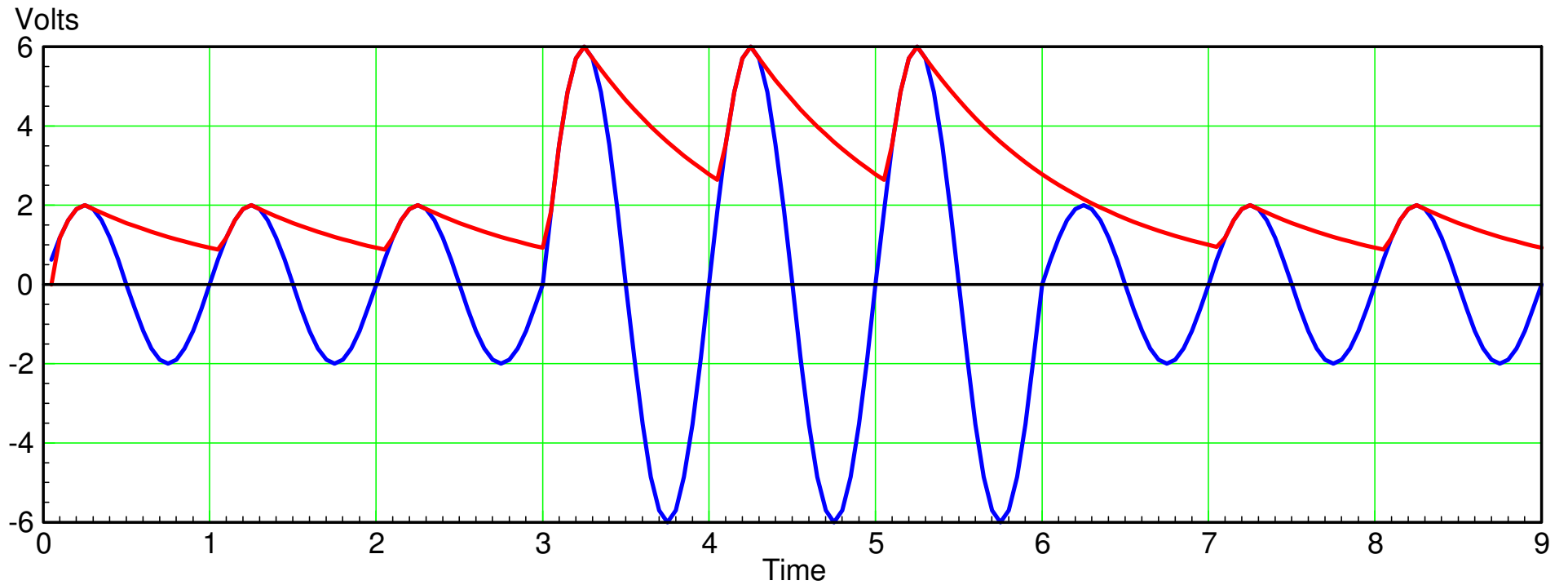

Envelope Detector: The output (red) tracks the amplitude of the input (blue)

Single-Sided Power Supplies

If instead you only had 0V and +5V available, treat 2.5V as circuit ground

- +5V behaves as +2.5V relative to circuit ground
- +2.5V behaves as +0V (circuit ground)
- +0V behaves as -2.5V relative to circuit ground.

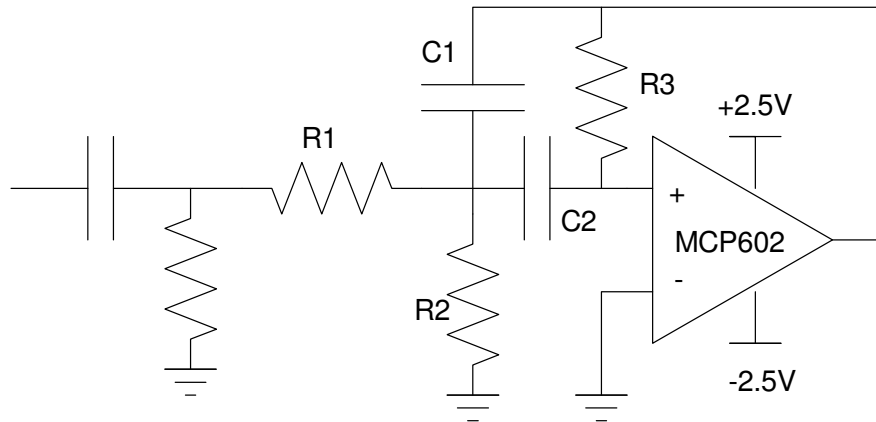

0V behaves as circuit ground

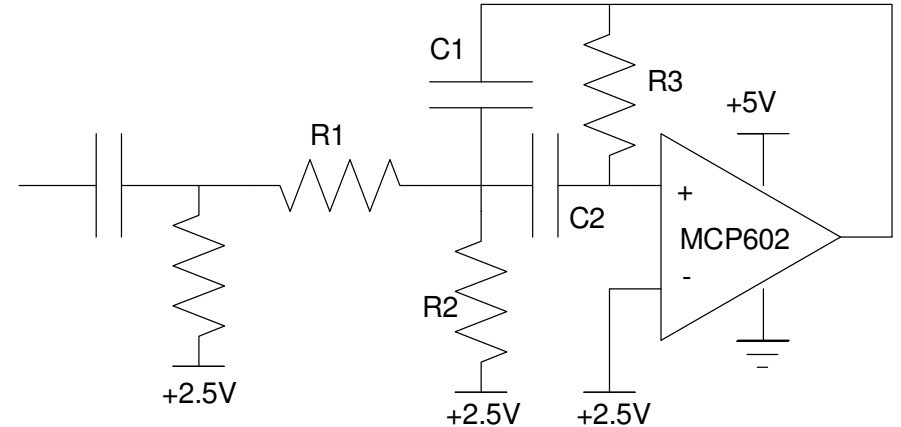

+2.5V behaves as circuit ground

Strain Gages

When you bend a piece of metal, the metal stretches (stress) or compresses (strain). A strain gage measures this change.

Approximate Elastic Constants

(from University Physics, Sears Zemansky, and Young, Reading, MA, 1979)

Material	Young's Modulus,
----------	---------------------

Solution: First, find the radius of curvature of the beam.

$$R^2 = (R - 5)^2 + 25^2$$

$$R = 65\text{mm}$$

Outer Edge Strain:

$$\epsilon = \left(\frac{65.5\text{mm} - 65\text{mm}}{65\text{mm}} \right) = +0.007692$$

Inner Edge Strain

$$\epsilon = \left(\frac{64.5\text{mm} - 65\text{mm}}{65\text{mm}} \right) = -0.007692$$

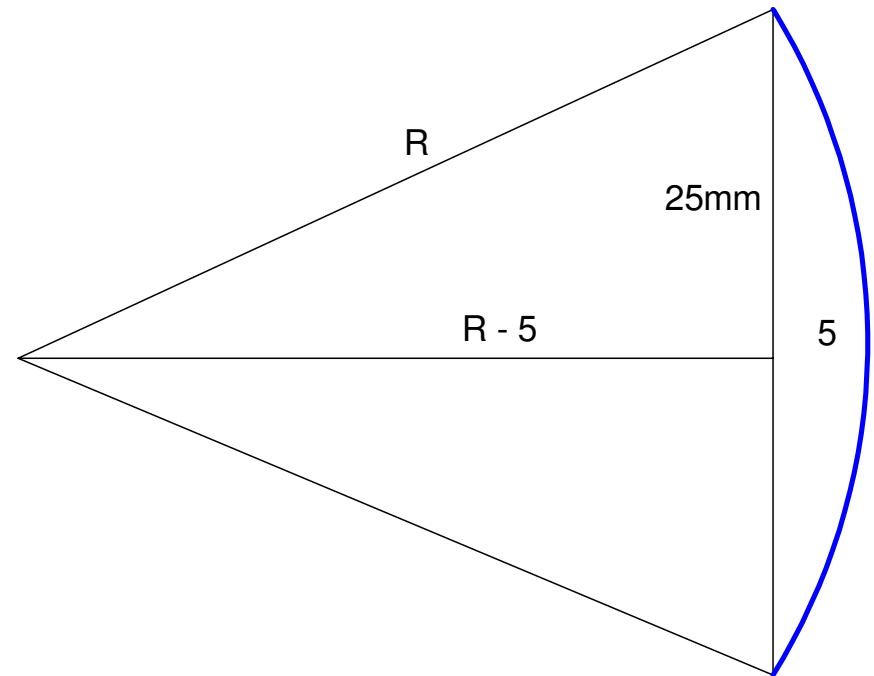

Example: Design a circuit to output 0V at 0 strain and +5V at 7.7mε. Use a strain gage with a nominal resistance of 120 Ohms and a gage factor of 2.14.

Solution: The resistance you're trying to measure is

$$R = 120(1 + 2.14\epsilon)$$

$$R(0) = 120\Omega$$

$$R(0.0077) = 121.977\Omega$$

Using an instrumentation amplifier and a voltage divider to convert this to 0V to 5V

0 Strain

$$X = 2.5V$$

0.0077 strain

$$X = \left(\frac{121.977}{121.911+120} \right) 5V = 2.5204V$$

$$gain = \left(\frac{5V-0V}{2.5204V-2.50V} \right) = 244.79$$

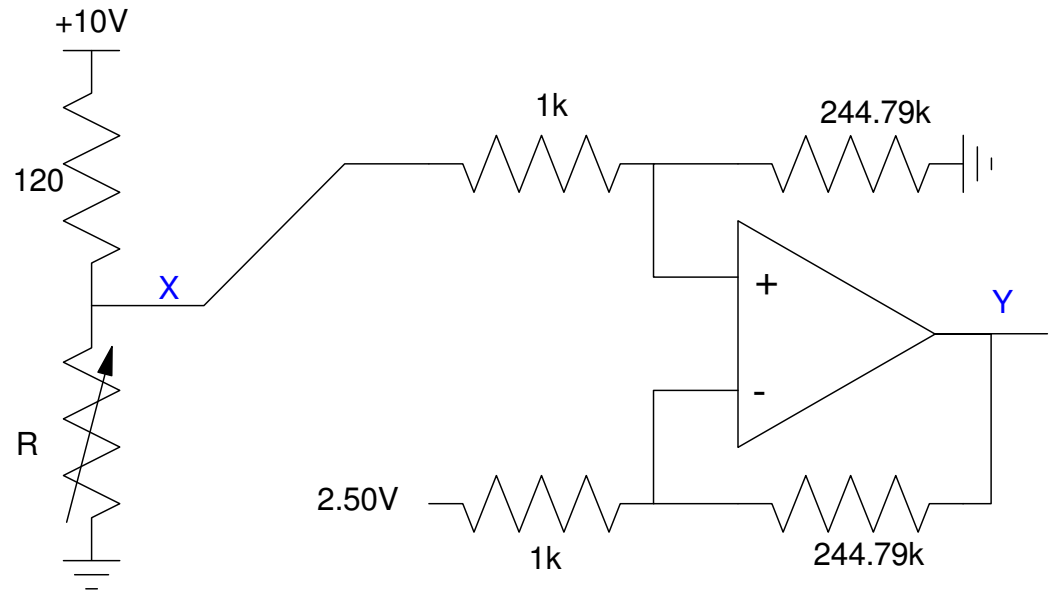

Variations:

Temperature Compensation: Since resistance also changes with temperature, the output will also change with temperature. To prevent this, replace resistor A with a second strain gage placed on the metal, perpendicular to the direction of strain.

Temperature Compensation with Double the Sensitivity: Replace resistor A with a strain gage placed on the other side of the bar. When one strain gage is under compression, the other is under tension, doubling the voltage change in the voltage divider.

Temperature Compensation with 4x the Sensitivity: Use four strain gages. B and C are placed on the inside surface, A and D are placed on the outside surface.

Uses of Strain Gages

1) Force Sensor: Design a mechanical system where strain is proportional to force. This is commonly used in electronic bathroom scales.

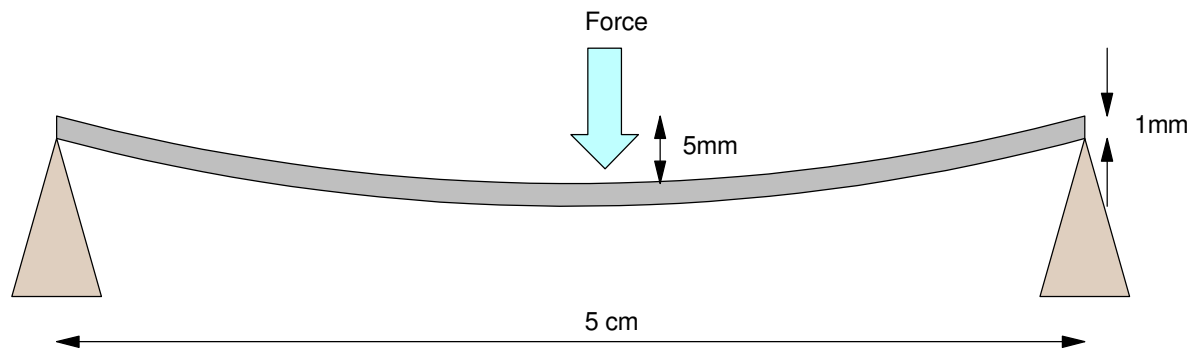

2) Pressure Sensor: Allow the force to be applied over a fixed area. The result measures force per unit area, or pressure.

3) Differential Pressure Sensor: Design a mechanical device where the strain is proportional to the difference in pressure: $P_1 - P_0$

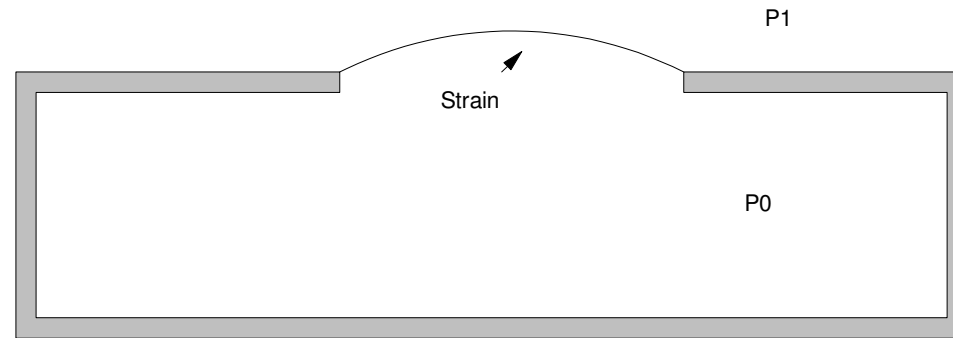

4) Accelerometer: Design a system where strain is related to acceleration.

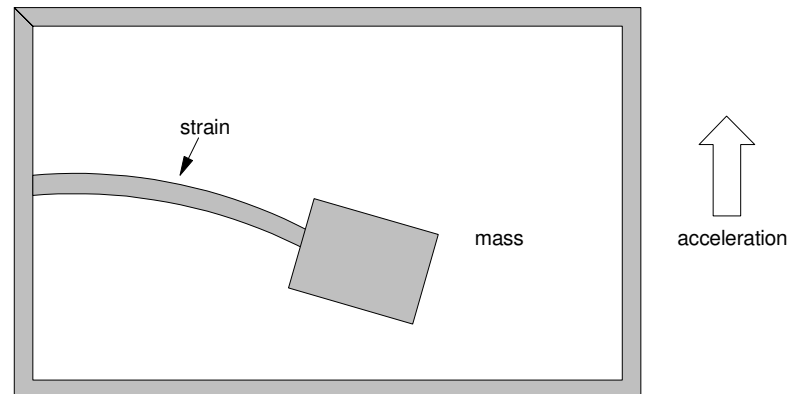

Summary

Acoustic Sensors

- Acoustic sensors convert sound to voltage
- An instrumentation amplifier can amplify the signal and remove the DC offset
- If you care about the amplitude of the audio signal, an envelope detector can be added

Strain Sensors

- Convert strain to resistance
 - An instrumentation amplifier can amplify the signal and remove the DC offset
 - Temperature compensation is often required
-