

ECE 321 - Homework #4

Butterworth & Chebychev filters, Analog Computers. Due Monday, April 26th

Please make the subject "ECE 321 HW#4" if submitting homework electronically to Jacob_Glower@yahoo.com (or on blackboard)

Analog Computers

1) Design an analog computer to implement

$$Y = \left(\frac{10s+15}{s^3+7s^2+2s+20} \right) U$$

Rewrite as

$$X = \left(\frac{1}{s^3+7s^2+2s+20} \right) U$$

$$Y = (10s + 15)X$$

Draw as an analog computer

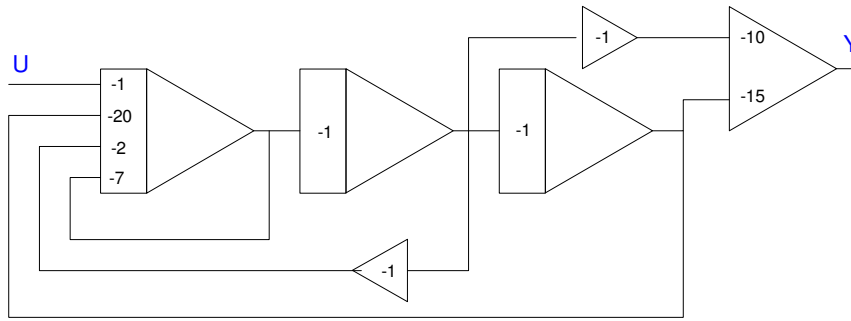

Replace each amplifier with its op-amp circuit

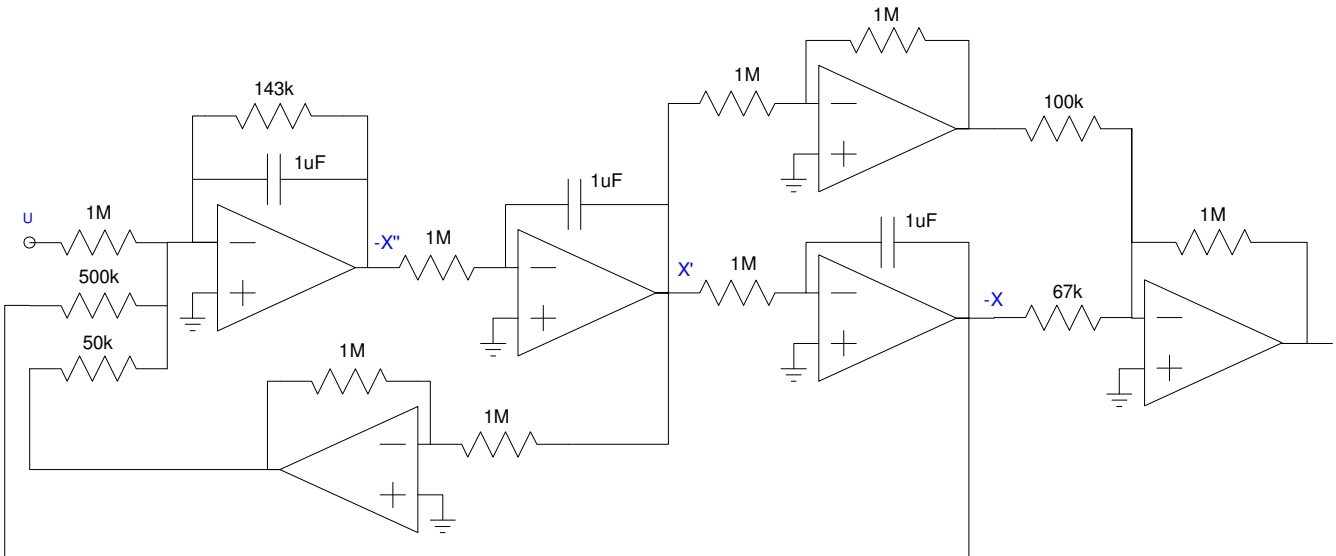

Butterworth and Chebychev Filters

2) Requirements. Specify

- The frequencies that should be passed ($0.9 < \text{gain} < 1.1$),
- The frequencies that should be rejected ($\text{gain} < 0.2$)

Option #1: Low Pass Filter

- $0.9 < \text{gain} < 1.1$ for frequencies between 20Hz and 250Hz
- $\text{gain} < 0.2$ for frequencies above 500Hz

3) Filter design:

- Give the transfer function for a filter which meets your requirements.
- Plot the gain vs. frequency of your filter.

The number of poles needed are

$$\left(\frac{250\text{Hz}}{500\text{Hz}}\right)^n < 0.2$$

$$n > 2.32$$

Let $n = 3$. Assume a Chebychev filter. For a corner at 1 rad/sec

$$G(s) = \left(\frac{1}{(s+0.85)(s+1.21\angle\pm 69.5^\circ)} \right)$$

For a corner at 238Hz (guess)

$$G(s) = \left(\frac{k}{(s+1275)(s+1815\angle\pm 69.5^\circ)} \right)$$

Checking in Matlab if this meets the requirements

```
>> f = [0:10:1000]';  
>> w = 2*pi*f;  
>> s = j*w;  
>> p1 = 1500 * 0.85;  
>> p2 = 1500 * 1.21 * exp(j*69.5*pi/180);  
>> p3 = conj(p2);  
>> G = p1*p2*p3 ./ ( (s+p1).*(s+p2).*(s+p3) );  
>> plot(f, abs(G), [250, 500], [0.9, 0.2], 'rx');
```

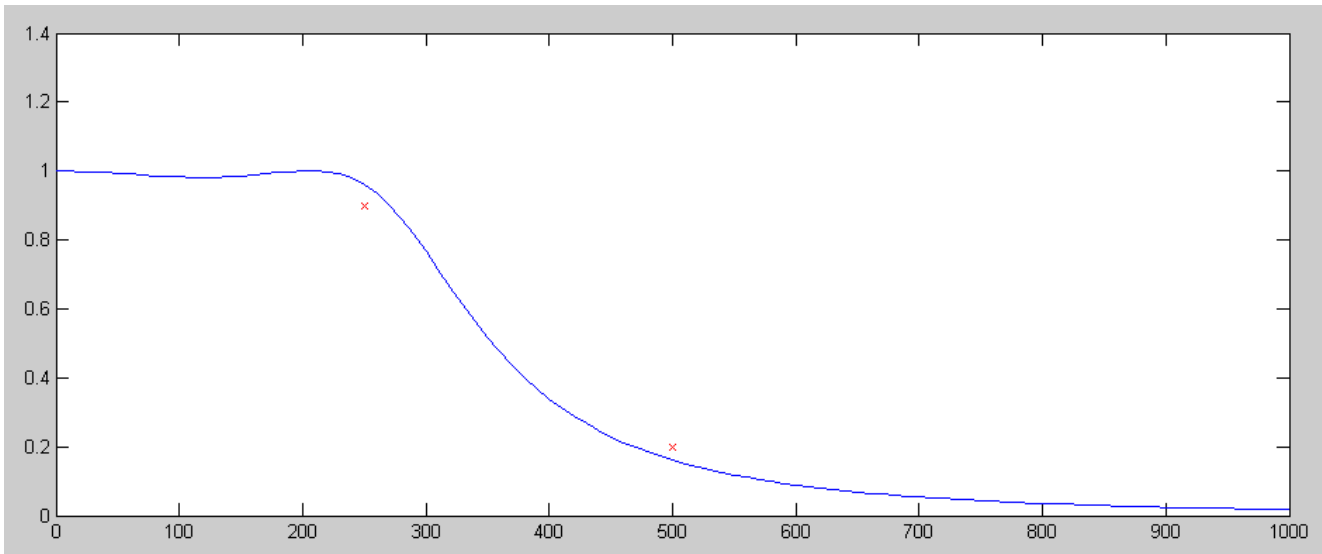

That works. To build this filter, do it in three stages

$$\left(\frac{1}{RC}\right) = 1275$$

$$R = 10\text{k}, C = 78\text{nF}$$

$$\left(\frac{1}{RC}\right) = 1815$$

$$R = 100\text{k}, C = 5.5\text{nF}$$

$$3 - k = 2 \cos(69.5^\circ)$$

$$k = 2.30$$

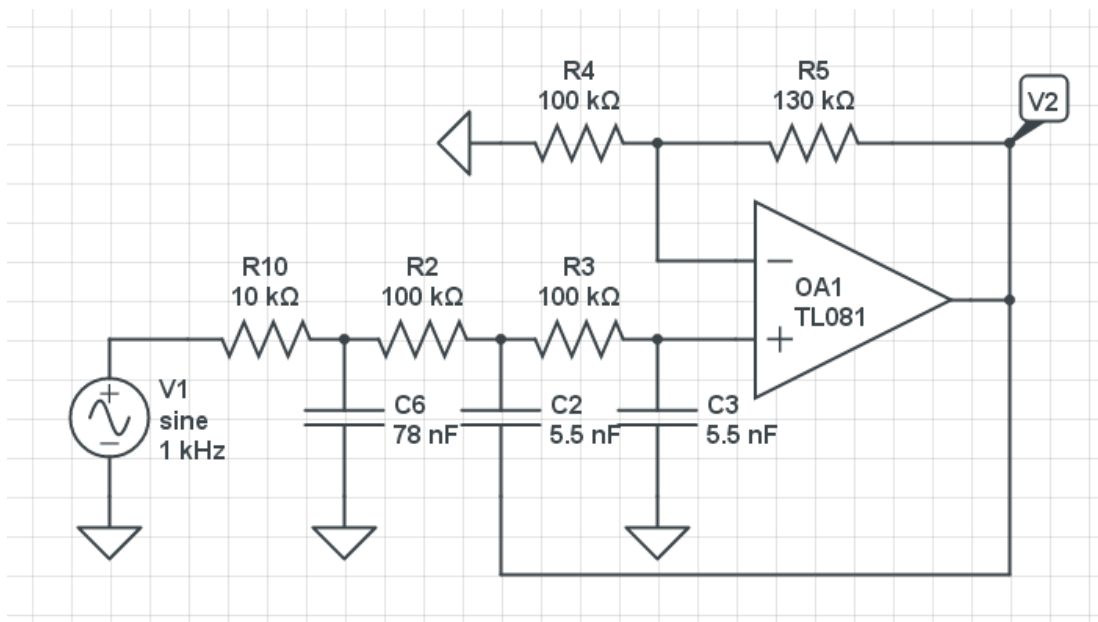

4) Simulation: Simulate your filter in CircuitLab to verify that it meets your requirements

- $0.9 < \text{gain} < 1.1$ in the pass-band region, and
- $\text{gain} < 0.2$ in the band-reject region

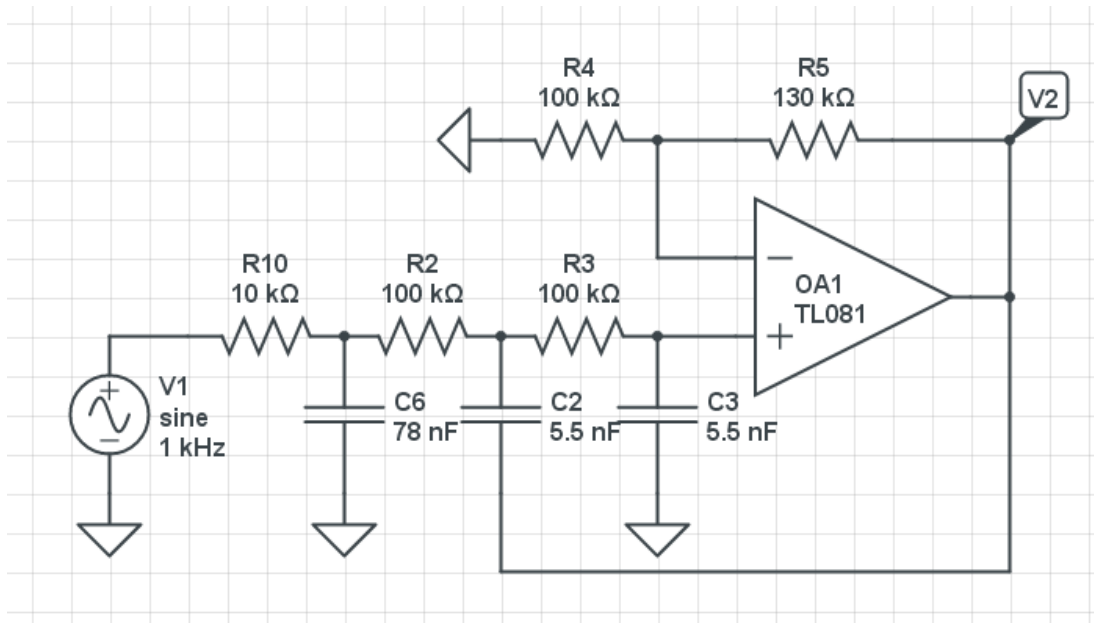
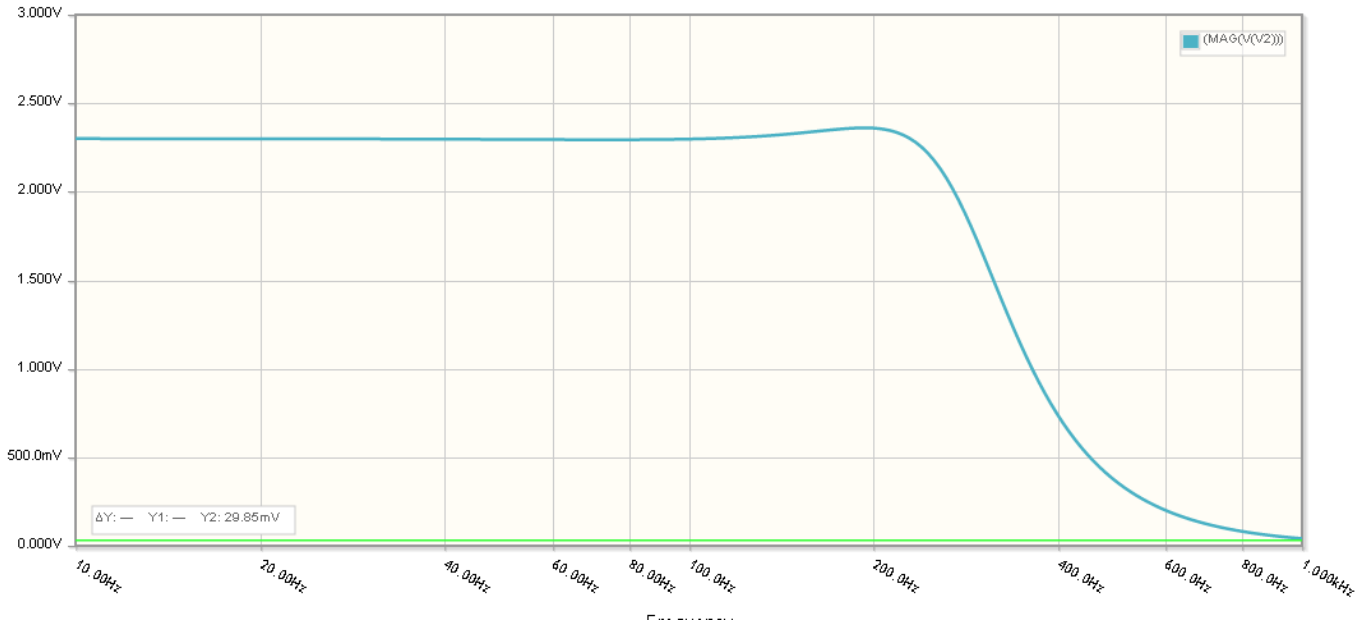

5) Hardware: Build your filter and verify it meets your requirements.

- $0.9 < \text{gain} < 1.1$ in the pass-band region, and
- $\text{gain} < 0.2$ in the band-reject region

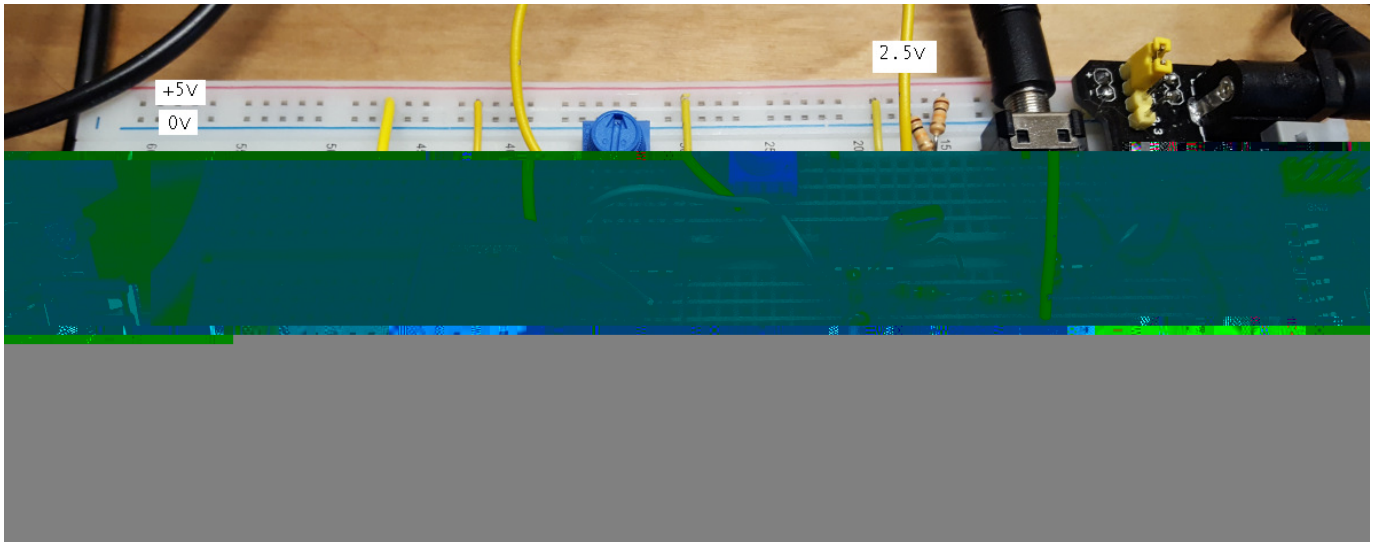

Hz	100Hz	250Hz	500Hz	1000Hz
Requirement	$1.1 < \text{gain} < 0.9$	$1.1 < \text{gain} < 0.9$	$\text{gain} < 0.2$	$\text{gain} < 0.2$
Gain (calculated)	0.9825	0.9606	0.1610	0.0177
Gain (CircuitLab)	0.9878	0.8693	0.1533	0.01813
Gain (measured)				

(all gains relative to the DC gain (2.300))

6) Demo: Demonstrate your pre-amp - filter - power amp circuit.