

ECE 321 - Homework #3

Filters. Due Monday, November 29th

1) X and Y are related by the following transfer function

$$Y = \frac{60}{(s+3)(s+10)} X$$

1a) What is the differential equation relating X and Y?

$$((s+3)(s+10))Y = (60)X$$

$$(s^2 + 13s + 30)Y = 60X$$

meaning

$$y'' + 13y' + 30y = 60x$$

1b) Find y(t) for

$$x(t) = 2 + 3 \cos(5t) + 4 \sin(5t)$$

Use superposition:

DC) $x(t) = 2$

$$s = 0$$

$$Y = \frac{60}{(s+3)(s+10)} \Big|_{s=0} (2 + j0) = 4$$

$$y(t) = 4$$

AC) $x(t) = 3 \cos(5t) + 4 \sin(5t)$

$$s = j5$$

$$X = 3 - j4$$

$$Y = \frac{60}{(s+3)(s+10)} \Big|_{s=j5} (3 - j4) = -3.459 - j3.035$$

$$y(t) = -3.459 \cos(5t) + 3.035 \sin(5t)$$

The total answer is DC + AC

$$y(t) = 4 - 3.459 \cos(5t) + 3.035 \sin(5t)$$

2) Design a circuit to implement

$$a) \quad Y = \frac{60}{(s+3)(s+10)} X$$

Use a 2-stage RC filter with an amplifier: $R_1 = 10k$, $R_2 = 100k$

$$\frac{1}{R_1 C_1} = 3 \quad C_1 = 33.3\mu F$$

$$\frac{1}{R_2 C_2} = 10 \quad C_2 = 1.00\mu F$$

The DC gain is 2.00. Add a non-inverting amplifier with a gain of 2

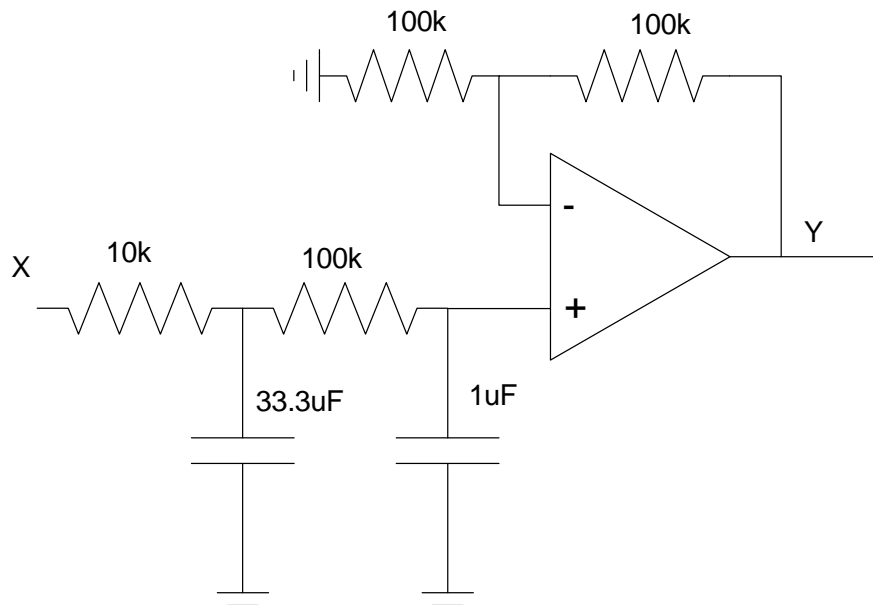

3) Design a circuit to implement

$$Y = \frac{60}{s^2+3s+30} X = \frac{20}{s^2+2s+37} X = \frac{60}{s+5.48 \angle \pm 74.1^\circ} X$$

Let $R = 100k$

$$\frac{1}{RC} = 5.48 \quad C = 1.825 \mu F$$

To set the angle

$$3 - k = 2 \cos(74.1^\circ)$$

$$k = 2.452 = 1 + \frac{R_1}{R_2}$$

Pick the feedback resistors in a 1.452 : 1 ratio

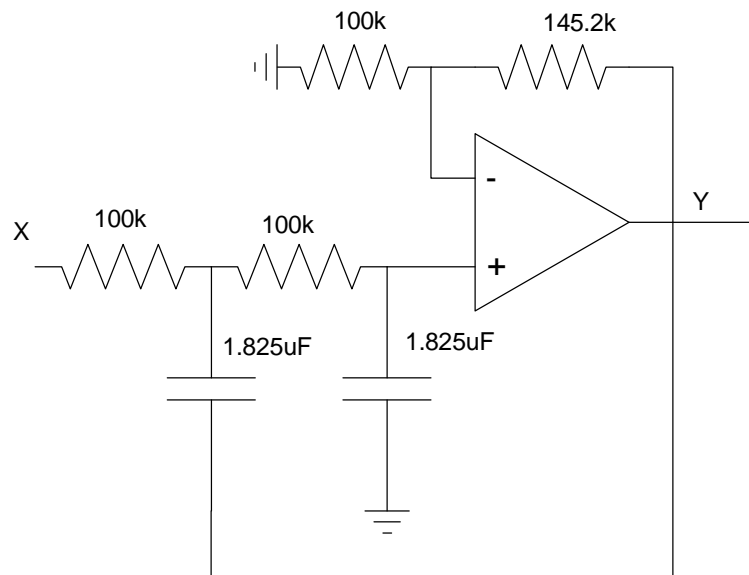

Filter Design using fminsearch()

3) Design a filter of the form

$$Y = \frac{ace}{(s+a)(s^2+bs+c)(s^2+ds+e)} X$$

to give a gain vs. frequency as close to $G_d(s)$ as possible over the range of (0,10) rad/sec

$$G_d(j\omega) = \begin{cases} 1 & \omega < 2 \\ 2 - 0.5\omega & 2 < \omega < 4 \\ 0 & \omega > 4 \end{cases}$$

Step 1: Create a function in Matlab where

- you pass your guess for {a,b,c,d,e}
- it compares the resulting $G(j\omega)$ to $G_d(j\omega)$, and
- returns the sum-squared error

```
function [ J ] = costf( z )
a = z(1);
b = z(2);
c = z(3);
d = z(4);
e = z(5);

w = [0:0.01:10]';
s = j*w;

Gideal = (1)*(w<2) + (2 - 0.5*w).*(w>=2).*(w<4);

G = a*c*e ./ ( (s+a).*(s.^2 + b*s + c) .* (s.^2 + d*s + e) );
G = abs(G);
E = abs(Gideal) - abs(G);

J = sum(E.^2);

plot(w,Gideal,w,abs(G),'r');
ylim([0,1.4]);
pause(0.01);
end
```

Example:

```
>> costF([1,2,3,4,5])
ans =
    88.5795
```

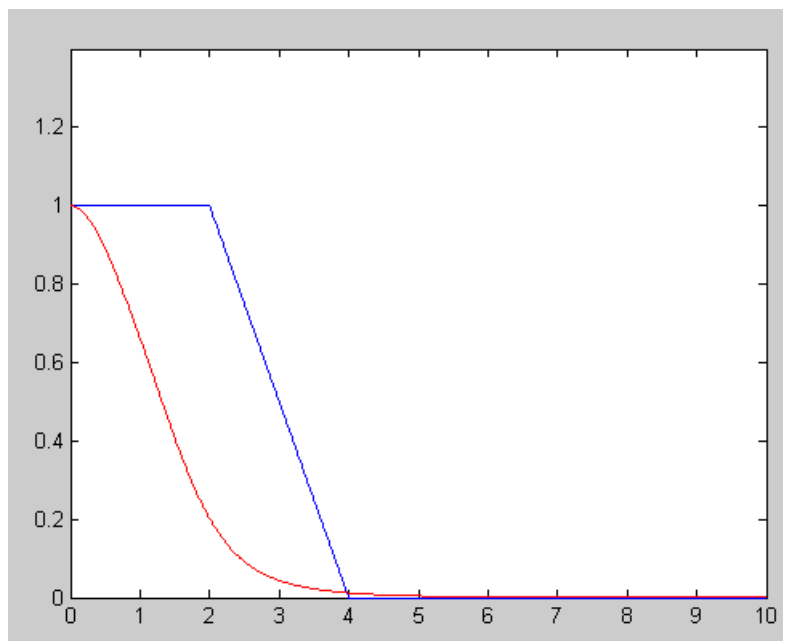

Step 2: Optimize the filter

```
>> [Z,e] = fminsearch('costF',[1,2,3,4,5])  
  
z =      a      b      c      d      e  
    =  1.1662  1.6631  3.9569  1.2334  9.2130  
  
e =  0.4984
```

meaning

$$G(s) = \frac{42.5149}{(s+1.1662) s^2+1.6631s+3.9569 \quad s^2+1.2334s+9.2130}$$

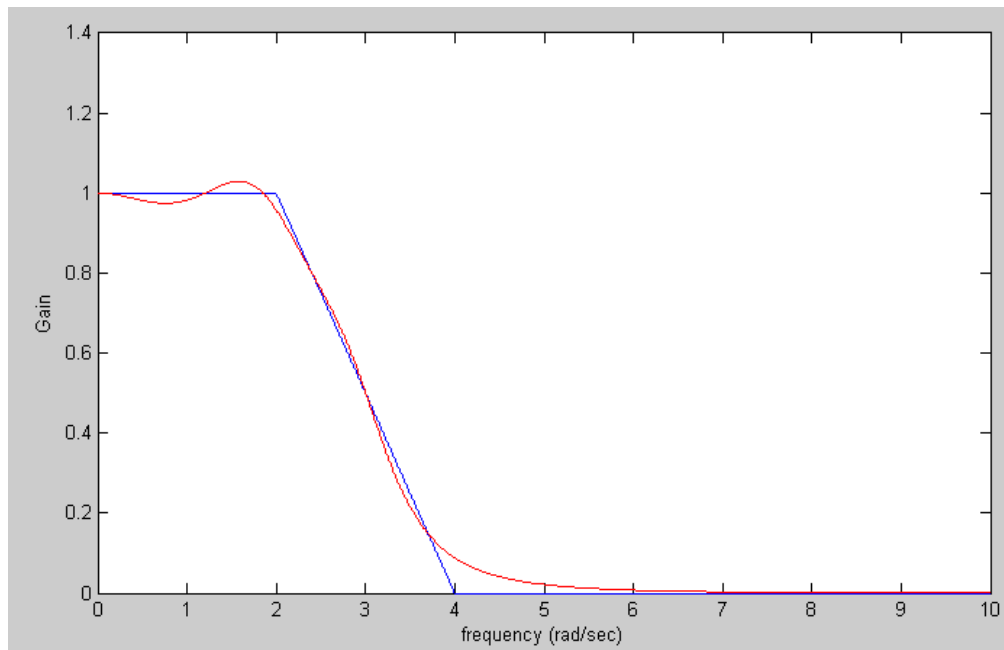

Problem 4-8) Add a filter to the amplifier from homework set #1

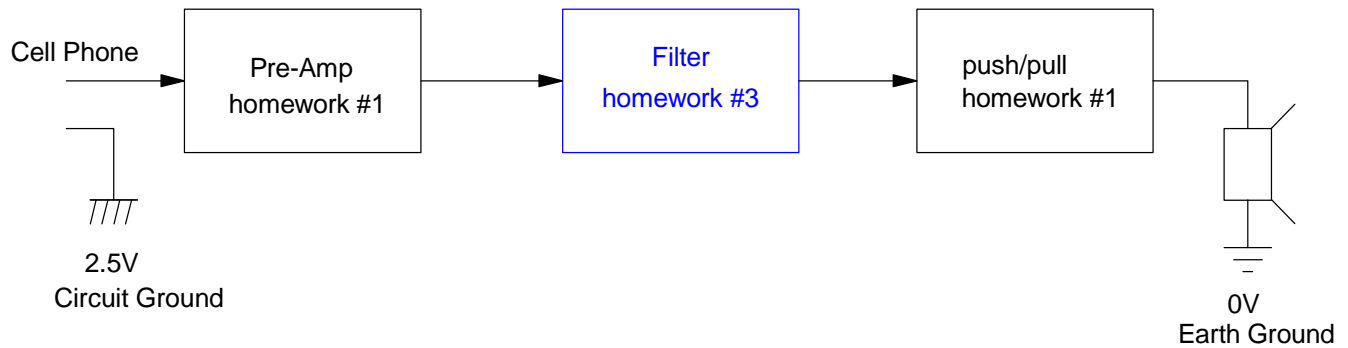

4) Requirements: Specify the requirements for a filter.

Option #1: Low Pass Filter

- $0.9 < \text{gain} < 1.1$ for frequencies between 20Hz and 250Hz
- $\text{gain} < 0.2$ for frequencies above 500Hz

5) Analysis: Design a filter to meet these requirements. Include in your calculations

The number of poles needed are

$$\frac{250\text{Hz}}{500\text{Hz}}^n < 0.2$$

$$n > 2.32$$

Let $n = 3$. Assume a Chebychev filter. For a corner at 1 rad/sec

$$G(s) = \frac{1}{(s+0.85) s+1.21\angle\pm 69.5^\circ}$$

For a corner at 238Hz (guess)

$$G(s) = \frac{k}{(s+1275) s+1815\angle\pm 69.5^\circ}$$

Checking in Matlab if this meets the requirements

```
>> f = [0:10:1000]';
>> w = 2*pi*f;
>> s = j*w;
>> p1 = 1500 * 0.85;
>> p2 = 1500 * 1.21 * exp(j*69.5*pi/180);
>> p3 = conj(p2);
>> G = p1*p2*p3 ./ ( (s+p1).*(s+p2).*(s+p3) );
>> plot(f, abs(G), [250, 500], [0.9, 0.2], 'rx');
```

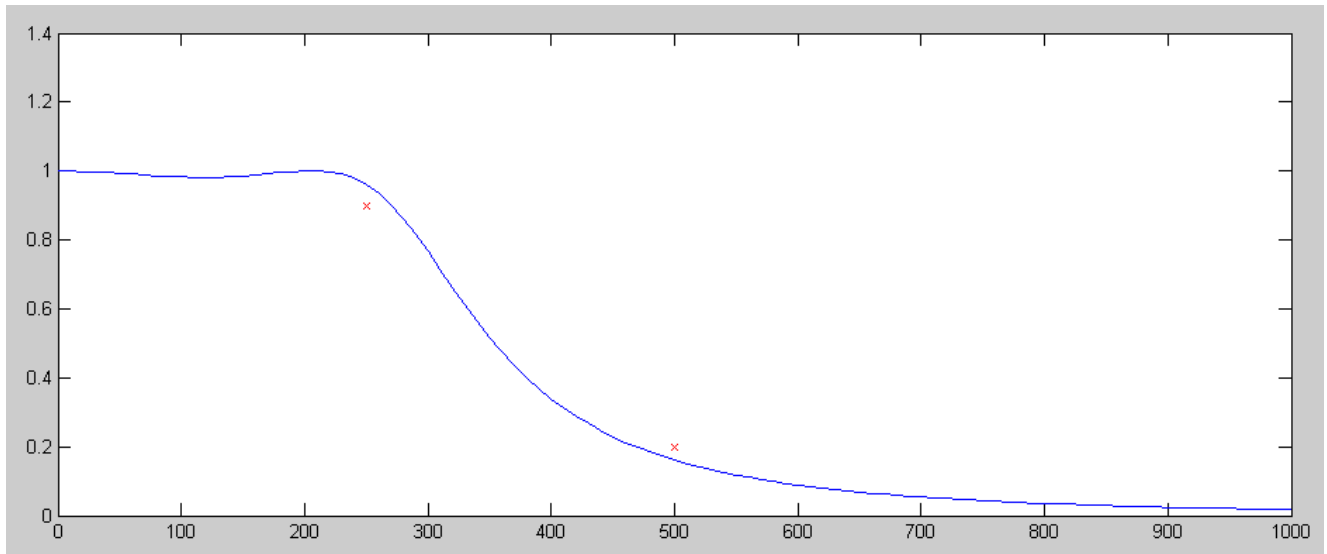

That works. To build this filter, do it in three stages

$$\frac{1}{RC} = 1275$$

$$R = 10k, C = 78nF$$

$$\frac{1}{RC} = 1815$$

$$R = 100k, C = 5.5nF$$

$$3 - k = 2 \cos(69.5^\circ)$$

$$k = 2.30$$

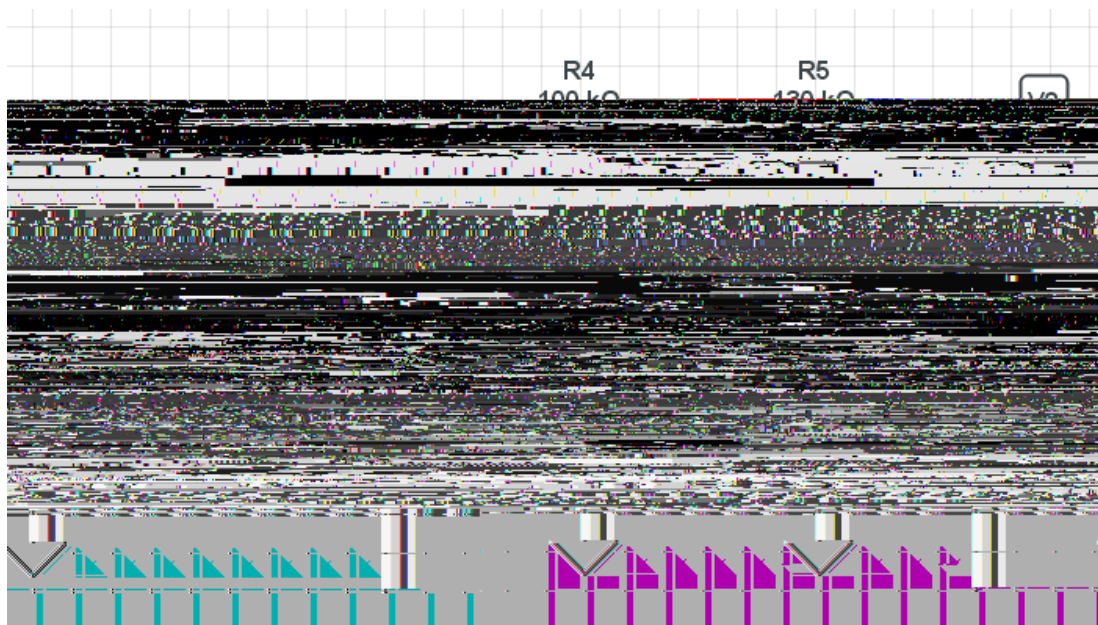

6) Simulation: Test your circuit design in CircuitLab (or similar program) to verify your design is correct

7) Validation: Build your circuit and take measurement to show that it does (or does not) meet your requirements

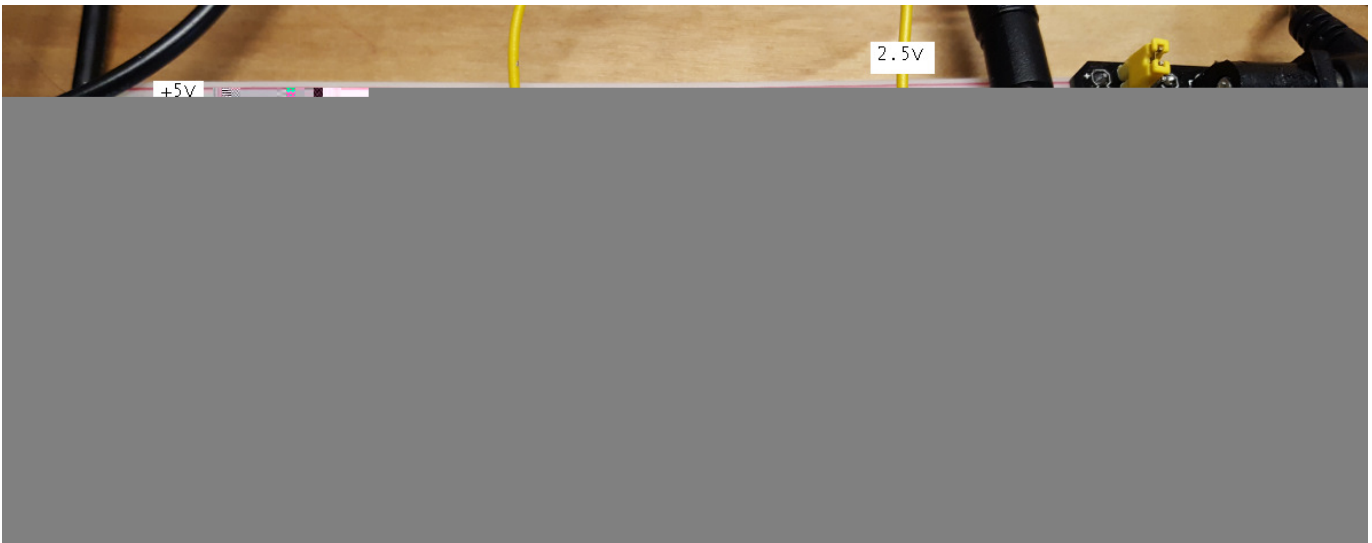

Hz	100	250	500	1,000
Gain (calculated)	2.26	2.2	0.37	0.04
Gain (measured)	2.26	1.74	0.36	0.15

8) Demo. Demonstrate your filter (live on zoom or with a video)