

# ECE 320 - Homework #8

DTL, TTL Logic Due Monday, March 6th  
Please email to [jacob.glower@ndsu.com](mailto:jacob.glower@ndsu.com), or submit as a hard copy, or submit on BlackBoard

## DTL Logic

- 1) Determine the voltages and currents for the following DTL OR gate. Assume 3904 NPN transistors
- 2) Simulate this circuit in CircuitLab to verify your answers

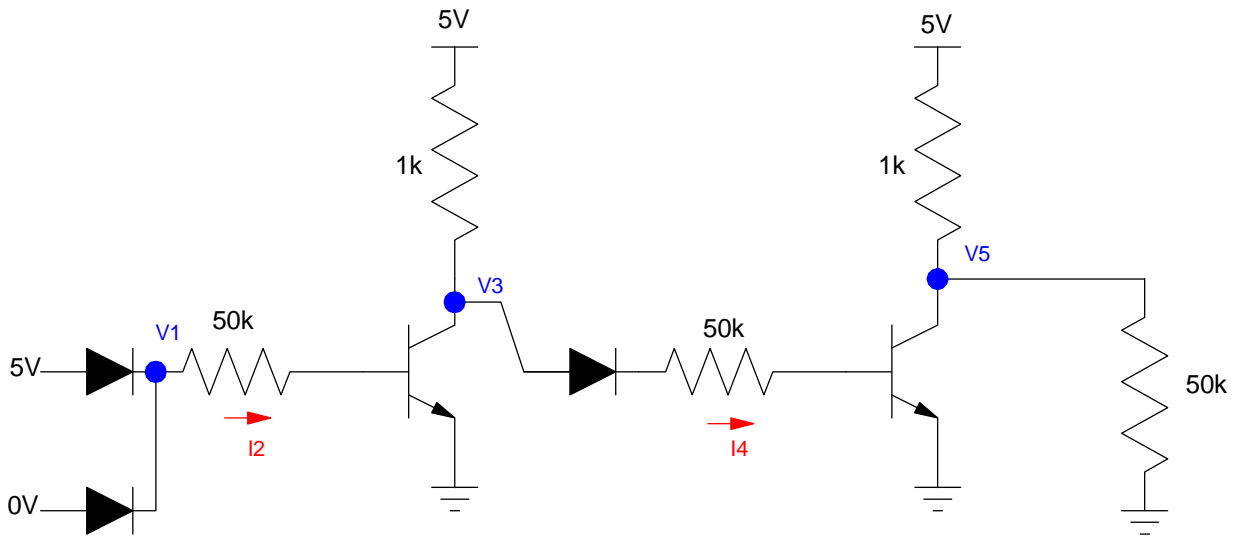

- 3) Determine the voltages and currents for the following DTL AND gate. Assume 3904 NPN transistors
- 4) Simulate this circuit in CircuitLab to verify your answers

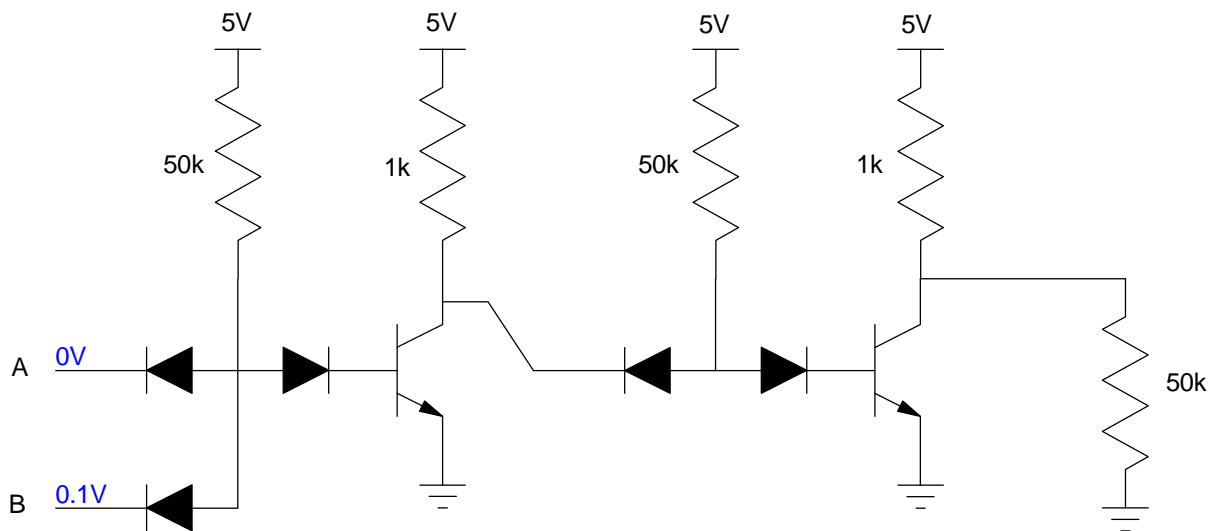

## TTL Logic

- Determine the voltages for the following TTL inverter. Assume 3904 transistors.
- Simulate these circuits in CircuitLab to verify your answers

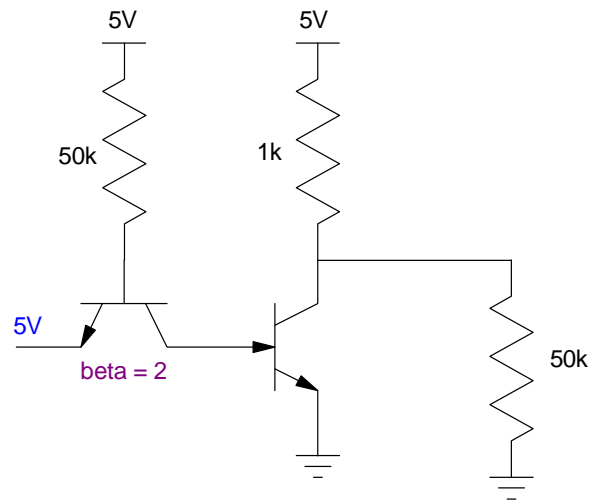
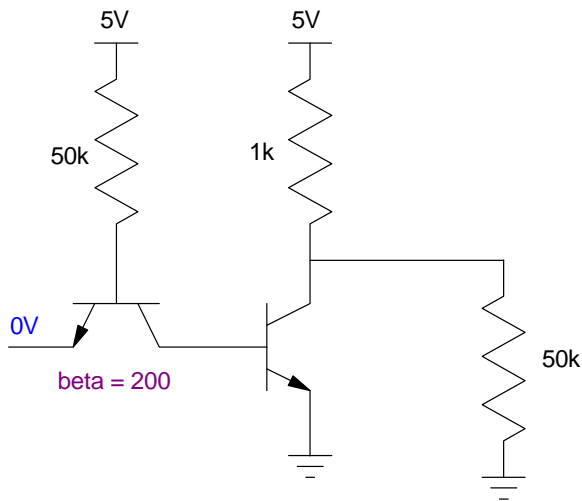

# Temperature Alarm using DTL Logic

The circuit below uses a DTL NAND gate to drive the speaker when

- The 555 timer outputs 5V, and
- The comparator outputs 5V,.

7) Determine the voltages when

- $V1 = V2 = 0V$
- $V1 = V2 = 5V$
- $V1 = 0V, V2 = 5V$

8) Verify your design using CircuitiLab.

**Lab: 9) (20pt):** Verify your design in hardware (build and test the circuit with your lab kit).

- note: Use a potentiometer to simulate the temperature sensor.

