

Quiz 7

Fourier Transform, DC to AC, SCR. Due March 16, 2022

En

The voltage V_1 is a 60% duty cycle square wave

$$V_1(t) = V_1(t + 1\text{ms}) \quad V_1 \text{ is periodic in } 1\text{ms} - \text{i.e. it's a } 1\text{kHz square wave}$$

$$V_1(t) = \begin{cases} +20\text{V} & 0 < t < 600 \text{ } \mu\text{s} \\ 0.7\text{V} & 600 \text{ } \mu\text{s} < t < 1000 \text{ } \mu\text{s} \end{cases}$$

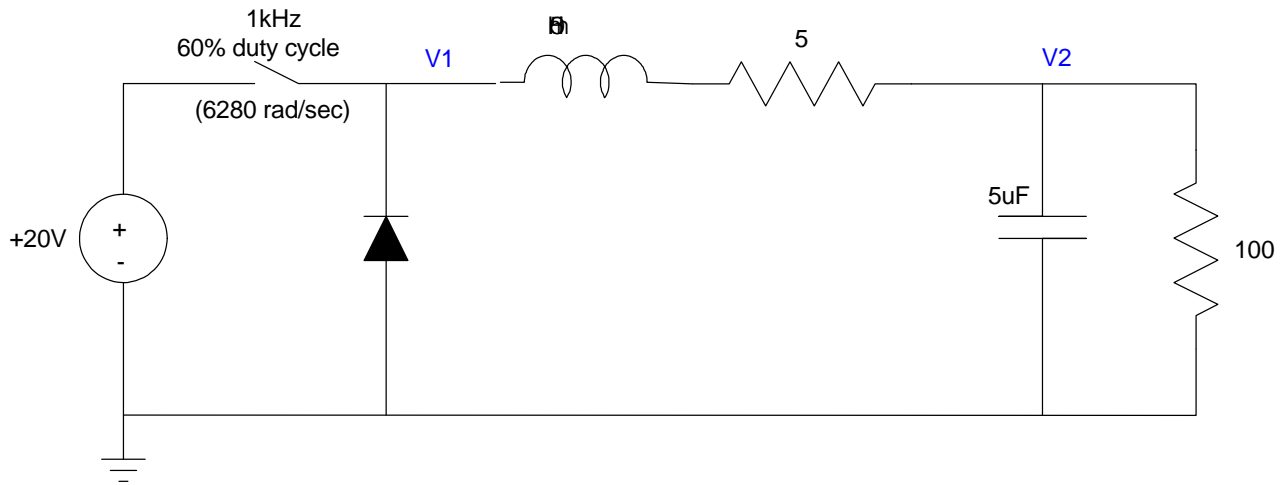

1) Determine the first five terms for the Fourier transform for $V_1(t)$

- DC
- 1kHz, sine and cosine
- 2kHz, sine and cosine

$$V_1(t) = a_0 + a_1 \cos(\omega t) + b_1 \sin(\omega t) + a_2 \cos(2\omega t) + b_2 \sin(2\omega t)$$

2) Determine $V_2(t)$ at each frequency

- DC
- 1kHz
- 2kHz

3) Compare the results from this homework set with homework set #6, problem #4 and #5.

- Does using the Fourier transform for $V_1(t)$ give more accurate results in predicting $V_2(t)$?

DC

4) Let

- A = 0V / 5V square wave, 60Hz, 0 degree time delay
- B = 0V / 5V square wave, 60Hz, 180 degree time delay
- C1 = 10uF

Determine using CircuitLab the voltage V2 (i.e. voltage across a DC motor, modeled as a 10 Ohm 100mH load)

5) Adjust C1 so that the voltage across the motor is as close to a sine wave as possible (trial and error)

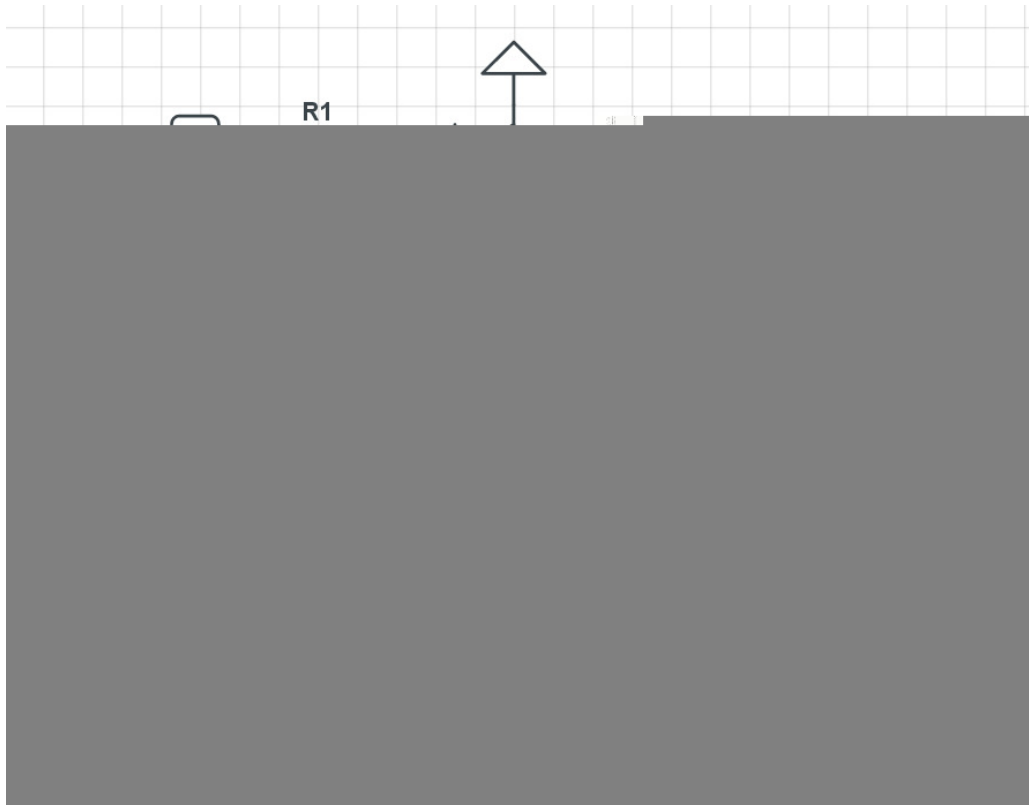

DC to AC Converter (problem 4 & 5)

B

6) Assume a firing angle of 25 degrees. Determine the voltage at V1 and V2 (both DC and AC).

7) Change this circuit so that

- The voltage at V2 is 8.00V (DC)
- With a ripple of 500mVpp

8) Simulate this circuit in Matlab by

- Writing the differential equations which describe the circuit (state variables: I_L and V_C)
- Specify $V_1(t)$ as a full-wave rectified sine wave clipped at X degrees (from problem #4)
- Use numerical integration to find $V_2(t)$

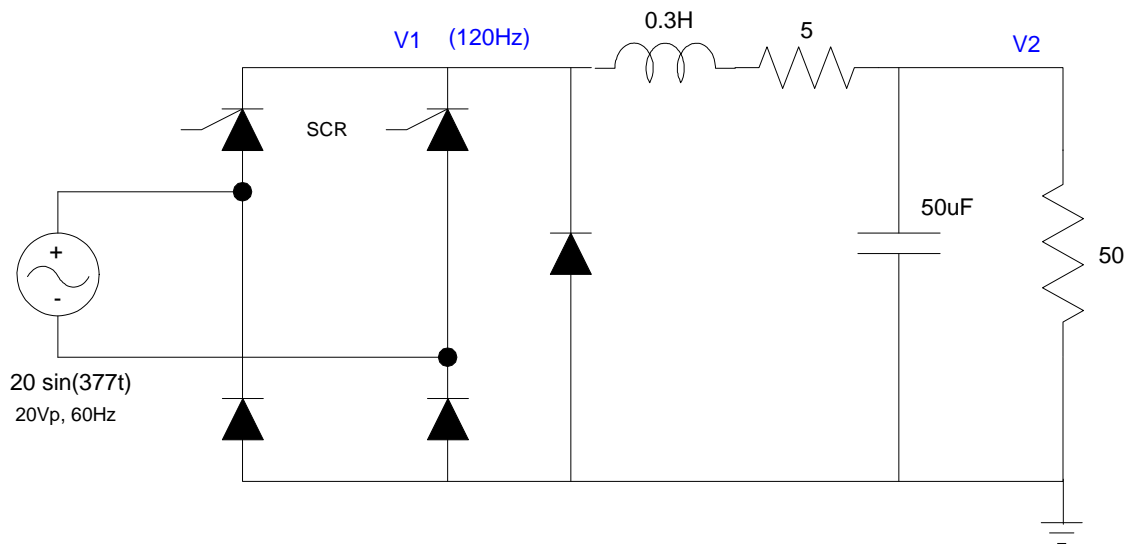

SCR: Problem 6 - 8