Phasor Impedances

EE 206 Circuits I

Jake Glower

03/18/20

Please visit *Bison Academy* for corresponding
lecture notes, homework sets, and solutions

Objective:

- Represent R, L, and C as a complex impedance
- Determine the impedance of RLC networks.

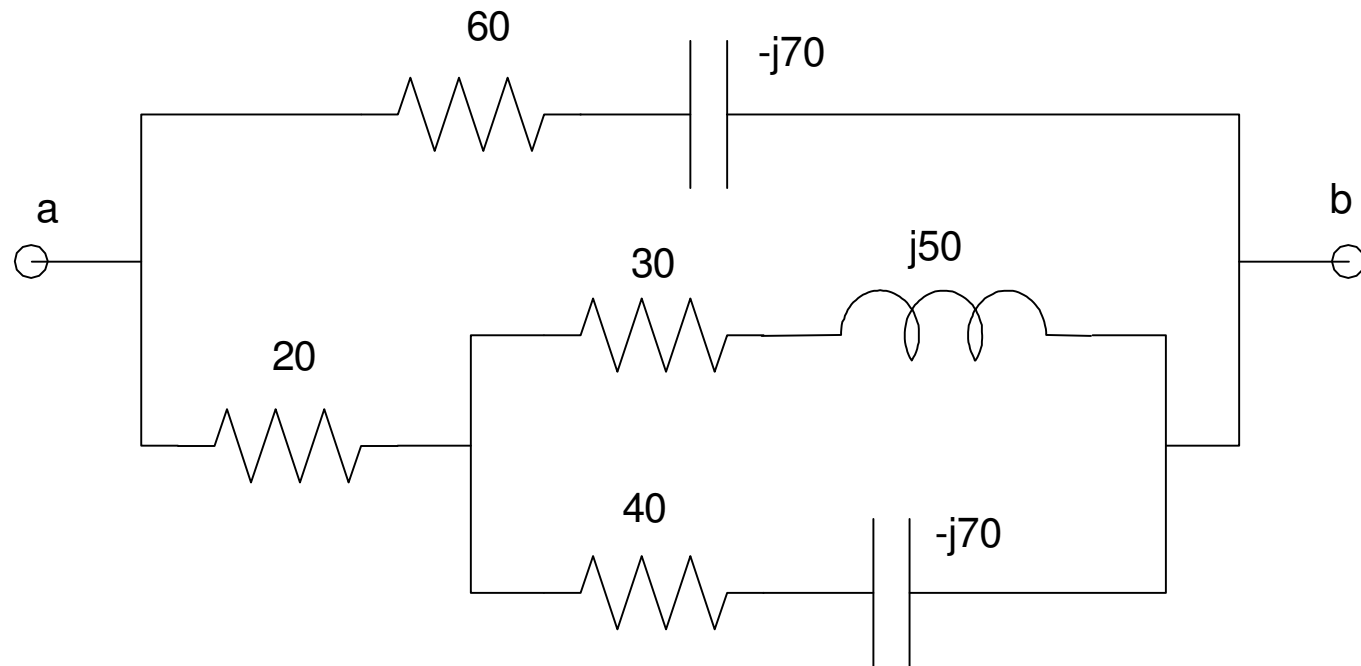

Resistors

From before, a current (or voltage)

$$i(t) = a \cos(\omega t) + b \sin(\omega t)$$

can be written in phasor form as

$$I = a - jb$$

The voltage produced by a current flowing through a resistor is

$$v(t) = i(t) \cdot R$$

or in phasor form

$$V = IR$$

The complex impedance of a resistor is R

Resistor VI Plot:

- $R = 883 \text{ Ohm}$
- Current is in phase with voltage for resistors.

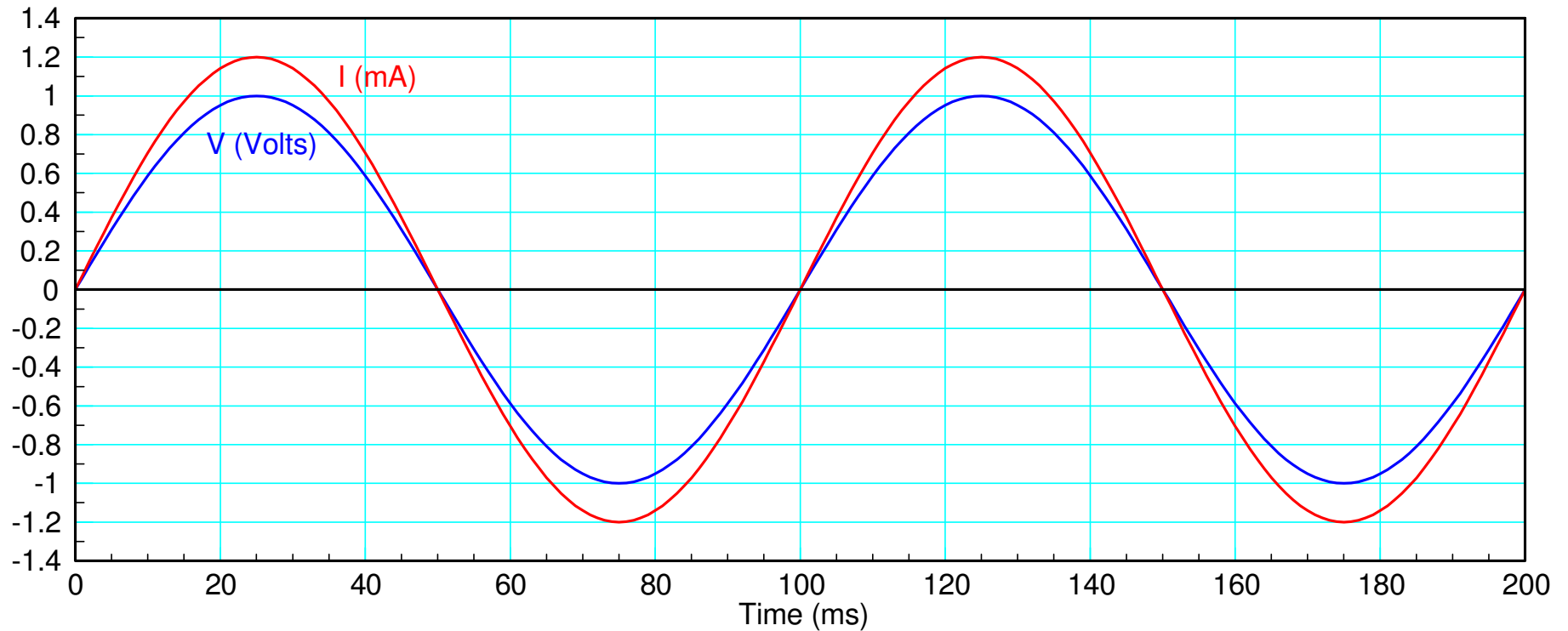

Voltage and current are in phase for resistors

Capacitors

The current through a capacitor is

$$i(t) = C \frac{dv(t)}{dt}$$

If $v(t)$ is a sinusoid:

$$v(t) = a \cos(\omega t) + b \sin(\omega t)$$

$$V = a - jb$$

then the current will be

$$i(t) = C \cdot \frac{d}{dt}(a \cos(\omega t) + b \sin(\omega t))$$

$$I = C \cdot (ja\omega + b\omega) = j\omega C \cdot (a - jb)$$

The impedance is then the ratio:

$$Z = \frac{V}{I} = \left(\frac{a-jb}{j\omega C \cdot (a-jb)} \right) = \left(\frac{1}{j\omega C} \right)$$

Capacitor VI Plot:

- $Z = -j883$ Ohms
- Current leads voltage for capacitors

$$Z = \frac{1}{j\omega C}$$

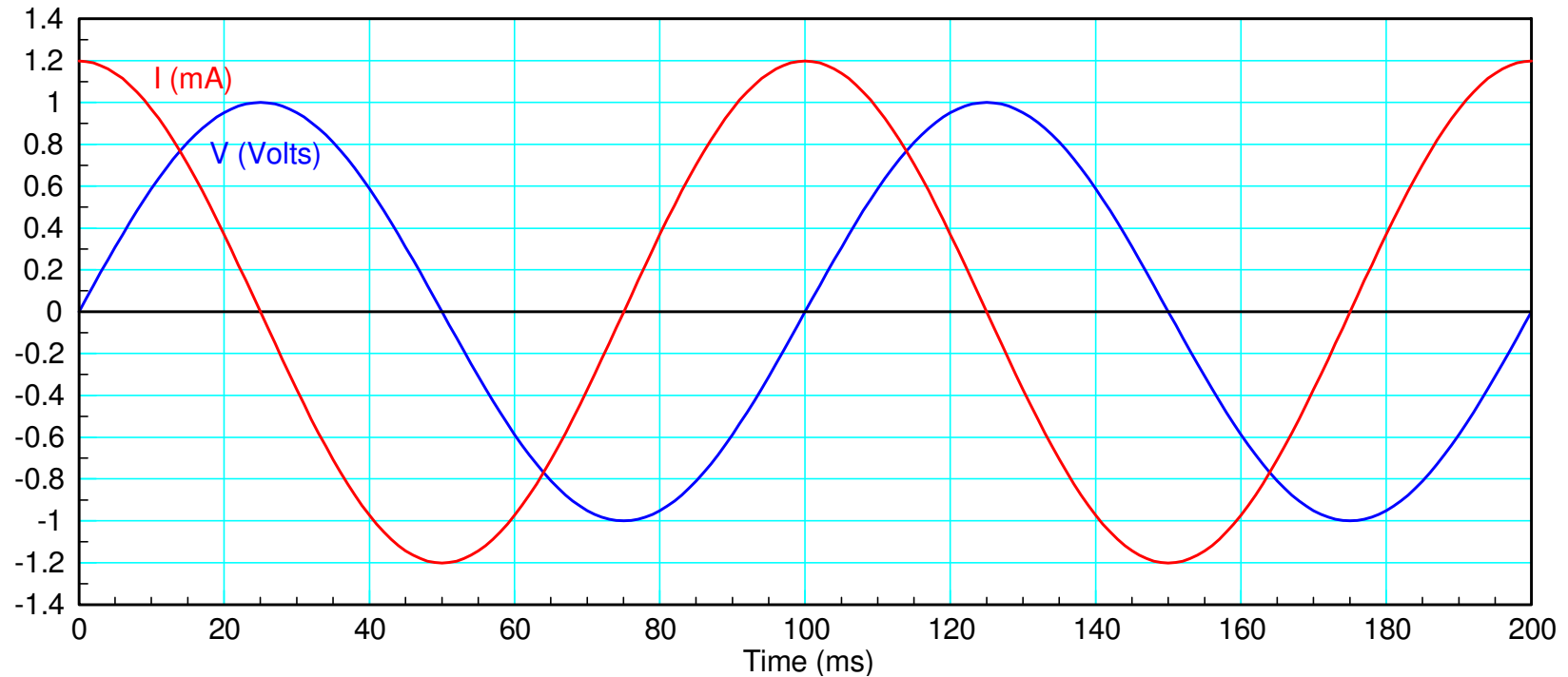

Inductors:

Current is related to voltage as

$$v(t) = L \frac{di(t)}{dt}$$

Assume

$$i(t) = a \cos(\omega t) + b \sin(\omega t)$$

$$I = a - jb$$

The voltage is then

$$v(t) = L \cdot \frac{d}{dt}(a \cos(\omega t) + b \sin(\omega t))$$

$$V = L\omega \cdot (ja + b) = j\omega L \cdot (a - jb)$$

$$Z = \frac{V}{I} = \left(\frac{j\omega L \cdot (a - jb)}{a - jb} \right) = j\omega L$$

Inductor VI Plot:

- $Z = +j883$ Ohms
- Voltage leads current for inductors

$$Z = j\omega L$$

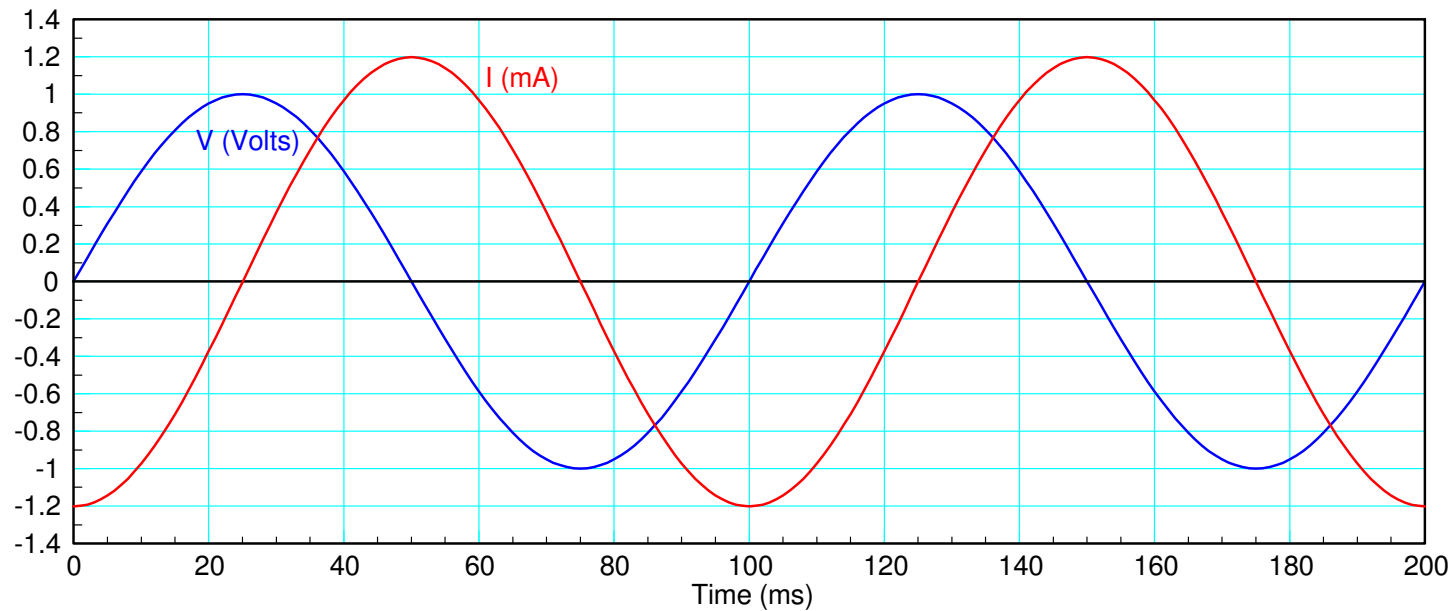

ELI the ICE Man

ELI: Voltage (E) leads current for inductors (L)

ICE: Current (I) leads voltage (E) for capacitors

RLC Example:

f (Hz)	0 Hz	100 Hz	10 kHz
ω (rad/sec)	0	628.3	62,831
R = 100 Ohms	Z = 100	Z = 100	Z = 100
L = 100mH	Z = 0	Z = j62.83	Z = j6283.1
C = 100uF	Z = infinity	Z = -j1591	Z = -j15.91

RLC Networks:

What works for real numbers works for complex numbers:

Example 1: Determine the complex impedance Z_{ab}

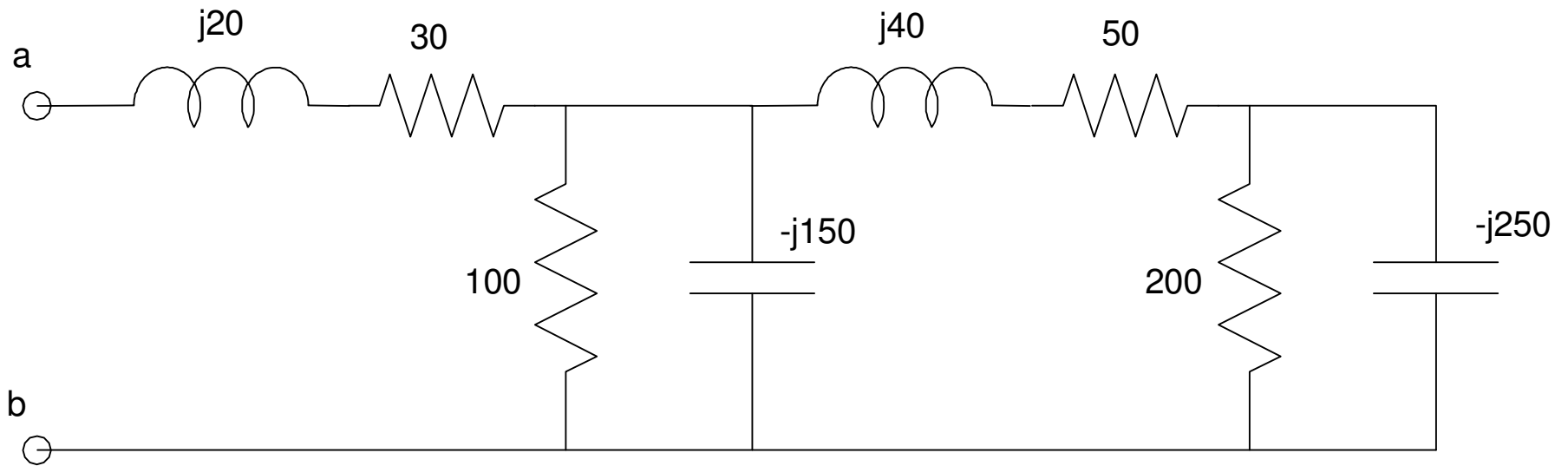

200 and $-j250$ are in parallel:

$$200 \parallel -j250 = \left(\frac{1}{200} + \frac{1}{-j250} \right)^{-1} = 121.95 - j97.56$$

This is in series with $(50 + j40)$ Ohms

$$(121.95 - j97.56) + (50 + j40) = 171.95 - j57.56$$

which is in parallel with $-j150$ and 100 Ohms

$$(171.95 - j57.56) \parallel (-j150) \parallel (100) = 50.30 - j27.80$$

which is in series with $20 + j30$ Ohms

$$(50.30 - j27.80) + (20 + j30) = 70.30 + j2.20$$

answer:

$$Z_{ab} = 70.30 + j2.20 \quad \text{Ohms}$$

note: it really helps to have a calculator that does complex numbers. I recommend an HP35s or the Free42 app on a cell phone

Example 2

Determine the complex impedance Z_{ab}

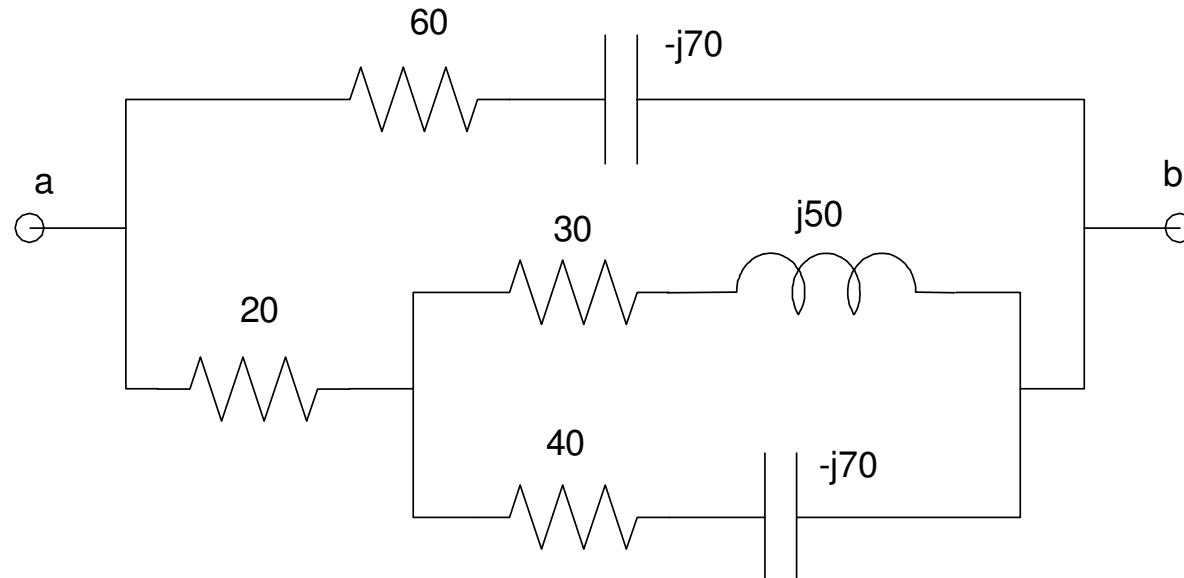

$$(40 - j70) \parallel (30 + j50) = 62.45 + j16.42$$

$$(62.45 + j16.42) + 20 = 82.45 + j16.42$$

$$(82.45 + j16.42) \parallel (60 - j70) = 48.56 - j15.34$$
