

More Thevenin and Norton Equivalents

Sometimes, the Thevenin resistance isn't obvious. In that case, you can apply a test voltage and calculate the resulting current draw. Then from $V = IR$, you can calculate the Thevenin resistance.

Example 1: Determine the Thevenin equivalent for the following circuit

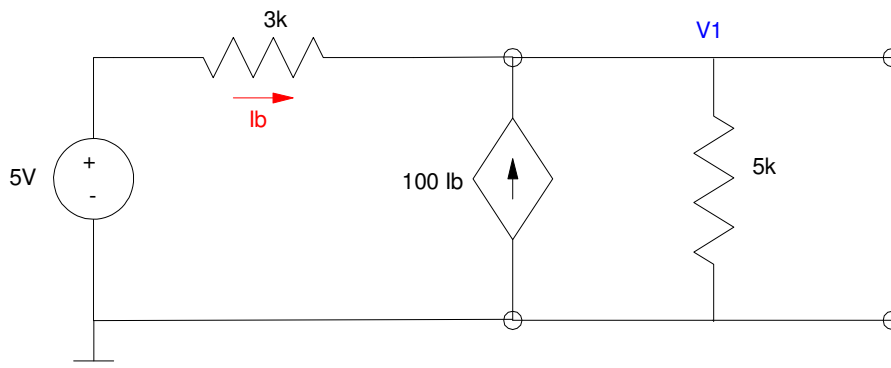

V_{th} : Determine the open-circuit voltage. Write the voltage node equation at V_1

$$I_b = \left(\frac{5 - V_1}{3k} \right)$$

$$\left(\frac{V_1 - 5}{3k} \right) - 100I_b + \left(\frac{V_1}{5k} \right) = 0$$

Substitute and solve

$$V_1 = \left(\frac{\left(\frac{100}{3k} \right)}{\left(\frac{100}{3k} \right) + \left(\frac{1}{5k} \right)} \right) 5V = 4.9705V$$

This is V_{th} .

To find R_{th} ,

- Turn off the voltage source
- Measure the resistance

This isn't obvious. In that case, apply a 1V test voltage and compute the current draw

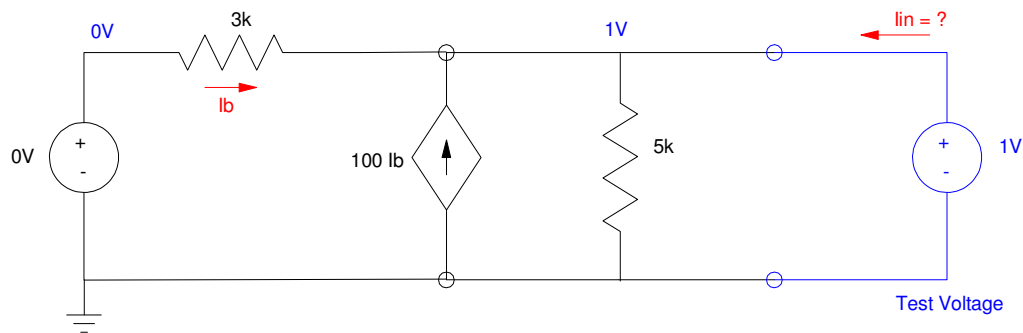

For this circuit

$$I_b = \left(\frac{0V-1V}{3k} \right)$$

$$I_{in} = \left(\frac{1V-0V}{3k} \right) - 100I_b + \left(\frac{1V}{5k} \right)$$

$$I_{in} = 33.87mA$$

So

$$R_{th} = \frac{V_{in}}{I_{in}} = \frac{1V}{33.87mA} = 29.53\Omega$$

The Thevenin equivalent is thus:

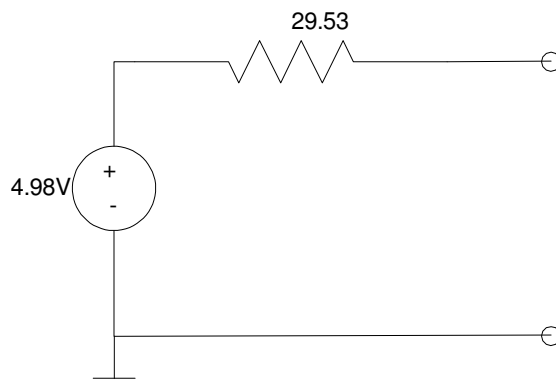

Example 2: Determine the Thevenin equivalent for the following circuit (this models an op-amp with a gain of -10: a circuit we'll cover later)

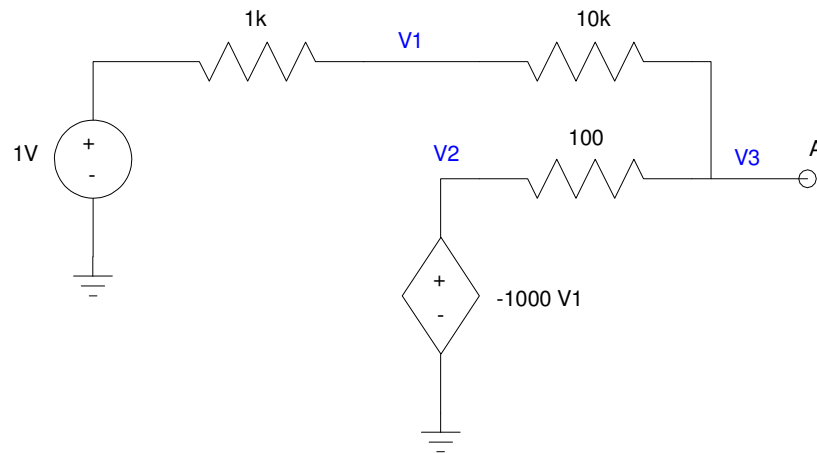

Example 2: Find the Thevenin equivalent of this active amplifier

Open-Circuit Voltage: Write the voltage node equations

$$V_2 = -1000V_1$$

$$\left(\frac{V_1-1}{1k}\right) + \left(\frac{V_1-V_3}{10k}\right) = 0$$

$$\left(\frac{V_3-V_1}{10k}\right) + \left(\frac{V_3-V_2}{100}\right) = 0$$

Solve (time passes....)

$$\begin{bmatrix} 1000 & 1 & 0 \\ 11 & 0 & -1 \\ -1 & -100 & 101 \end{bmatrix} \begin{bmatrix} V_1 \\ V_2 \\ V_3 \end{bmatrix} = \begin{bmatrix} 0 \\ 10 \\ 0 \end{bmatrix}$$

```
>> A = [1000, 1, 0; 11, 0, -1; -1, -100, 101]
```

$$\begin{array}{ccc} 1000 & 1 & 0 \\ 11 & 0 & -1 \\ -1 & -100 & 101 \end{array}$$

```
>> B = [0; 10; 0]
```

$$\begin{array}{c} 0 \\ 10 \\ 0 \end{array}$$

```
>> inv(A) * B
```

```
V1    0.0100
V2   -9.9891
V3   -9.8901
```

The net results is the open-circuit voltage is -9.8901V. This is V_{th} .

Thevenin Resistance: Turn off voltage sources and measure the resistance. Since this isn't obvious, apply a 1V test voltage and compute the current the circuit draws: