

Voltage and Current Division

Voltage Division

Problem: Generate a voltage that is X% of the input voltage.

Solution: Use two resistors in series:

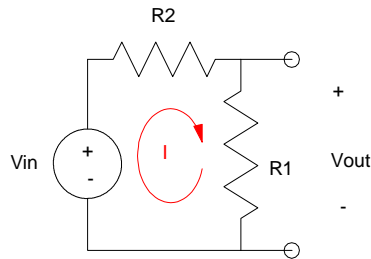

Voltage Divider: Two resistors reduce the input voltage

$$I = \frac{V_{in}}{R_1 + R_2}$$

$$V_{out} = I \cdot R_1$$

$$V_{out} = \frac{R_1}{R_1 + R_2} V_{in}$$

Example: Reduce the voltage from a car battery (13.2V) to 5V so that a microcontroller can read the voltage.

Solution: Let

$$\frac{R_1}{R_1 + R_2} = \frac{5V}{13.2} = 0.379$$

To limit the current to a safe level, let

$$R_2 = 1M \text{ Ohm}$$

Then

$$R_1 = 610k \text{ Ohms}$$

Note that the voltage is 5.00V *provided* there is no current drawn at Vout. This circuit works provided that the total resistance of R1 in parallel with the load is 610 k Ohms.

Potentiometers:

A potentiometer is a resistor where a third terminal (termed the wiper) picks off the voltage part way across the resistor. For example, in the picture shown below a resistor consisting of a long wire wound around a ceramic torous connects the two outer leads. A wiper connects a center tap part way along the length of the potentiometer.



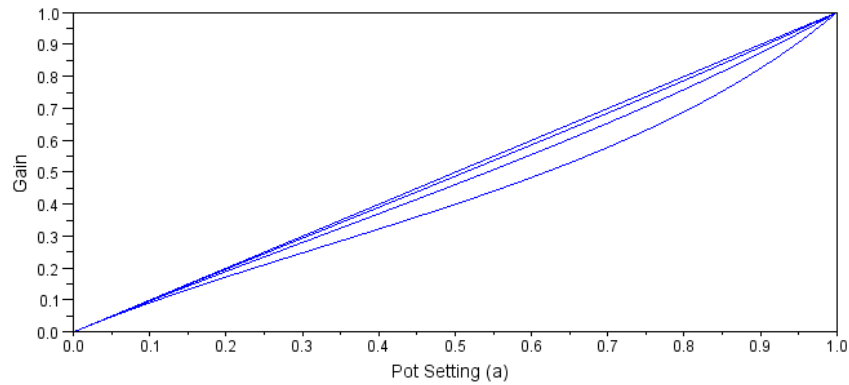

Gain of a potentiometer with a load of (infinite, 10x, 3x, 1x) the resistance of the potentiometer

Note that with a load placed at the wiper, the gain still goes from 0 to 1 regardless of the load. As long as the load is 3x the resistance of the potentiometer, the gain is almost linear.

Potentiometers Used as a Variable Resistor

A second use of potentiometers is to provide an adjustable resistor in a circuit. By shorting the wiper to one end, the resistance between the ends is adjustable from 0% to 100% of the total resistance.

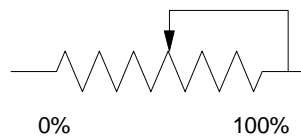

Potentiometer used as a variable resistor

Note that it is not necessary to short the wiper to one end, but this is customary. When a potentiometer fails, usually the wiper breaks. With the above configuration, the resistance becomes 100% when the wiper breaks. If you just connect one end to the wiper (without connecting to the other end), the resistance becomes infinite when the wiper breaks. As the design engineer, it's your choice as to what you want to happen upon failure.

Current Division

Problem: Find the currents I_1 and I_2

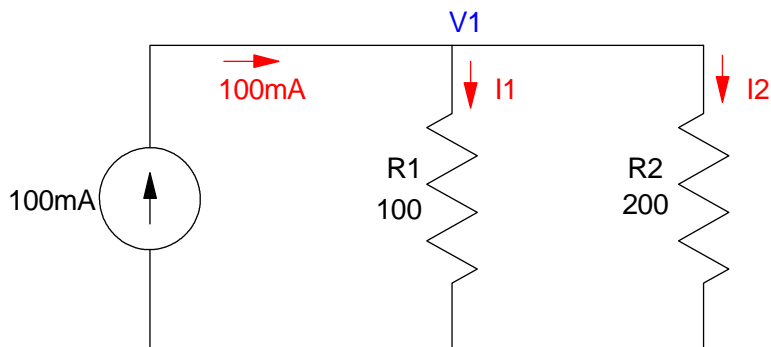

Solution: Find the voltage, V_1

$$R = R_1 || R_2 = \frac{1}{R_1} + \frac{1}{R_2}^{-1}$$

$$V = IR = 100mA \cdot \frac{1}{\frac{1}{R_1} + \frac{1}{R_2}}$$

The current, I_1 , is

$$I_1 = \frac{V_1}{R_1} = \frac{\frac{1}{R_1}}{\frac{1}{R_1} + \frac{1}{R_2}} \cdot 100mA$$

and

$$I_2 = \frac{V_1}{R_2} = \frac{\frac{1}{R_2}}{\frac{1}{R_1} + \frac{1}{R_2}} \cdot 100mA$$

Current Division: The current through a resistor is

$$I_x = \frac{\text{The admittance (1/R) of what you're measuring}}{\text{The total (sum) admittance}} \cdot \text{Current In}$$

For this problem

$$I_1 = \frac{\frac{1}{100}}{\frac{1}{100} + \frac{1}{200}} \cdot 100mA = 66.7mA$$

$$I_2 = \frac{\frac{1}{200}}{\frac{1}{100} + \frac{1}{200}} \cdot 100mA = 33.3mA$$

If you have more than one resistor, change it so that you have only two resistors

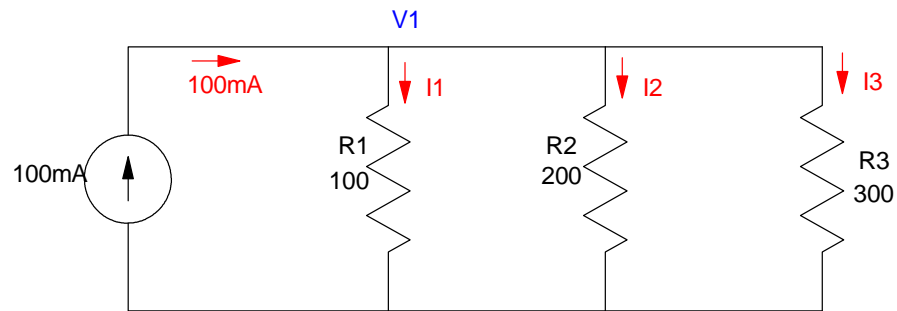

From before

$$I_1 = \frac{\frac{1}{100}}{\frac{1}{100} + \frac{1}{200} + \frac{1}{300}} \cdot 100mA = 54.5mA$$

$$I_2 = \frac{\frac{1}{200}}{\frac{1}{100} + \frac{1}{200} + \frac{1}{300}} \cdot 100mA = 27.3mA$$

$$I_3 = \frac{\frac{1}{300}}{\frac{1}{100} + \frac{1}{200} + \frac{1}{300}} \cdot 100mA = 18.2mA$$

Note that

$$I_1 + I_2 + I_3 = 100mA$$

Current Out = Current In