

EE 206: Homework #9

Passive Circuit Elements, Series and Parallel with Phasors, Voltage Nodes. Due Monday, November 9th

Please make the subject "EE 206 HW#9" if submitting homework electronically to lauren.n.singelmann@ndsu.edu (or on blackboard)

- 1) Determine the impedance of a resistor, inductor, and capacitor at 10, 1000, and 10k rad/sec

	R = 100 Ohms	L = 10mH	C = 10uF
10 rad/sec			
100 rad/sec			
1000 rad/sec			

- 2) Find the impedance Z_{ab} for the following circuit at 200 rad/sec
3) Find the impedance Z_{ab} for the following circuit at 300 rad/sec

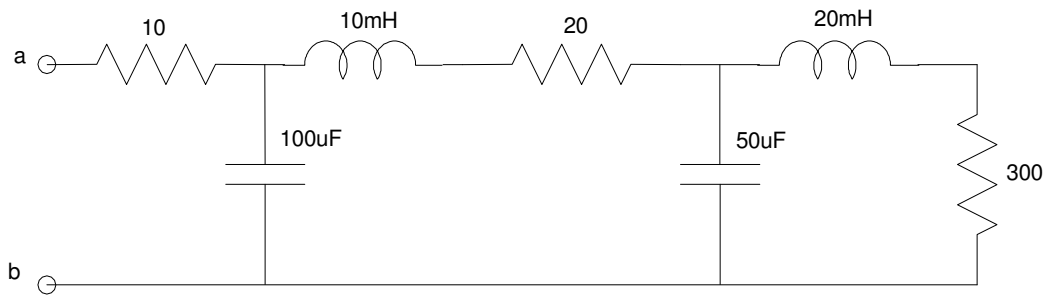

Problem 2 & 3

Problem 4: Assume $V_{in} = 10 \cos(200t)$

- Write the voltage node equations for the following circuit.
- Solve for V1, V2, and V3

Problem 5) Simulate the circuit of problem #4 in CircuitLab (or similar program) and compare the simulation results to your results from problem #4.

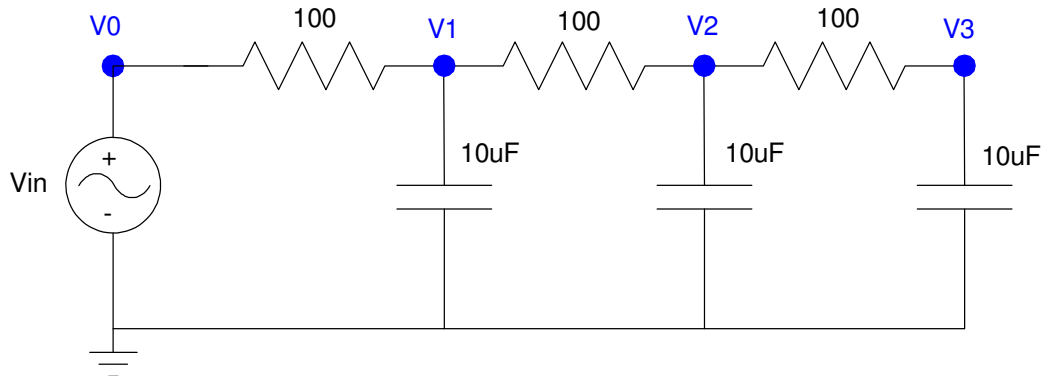

Problem 4 & 5

Problem 6: Assume

$$V_{in} = 10 \cos(200t)$$

- Write the voltage node equations for the following circuit.
- Solve for V1, V2, and V3

Problem 7) Simulate the circuit of problem #6 in CircuitLab (or similar program) and compare the simulation results to your results from problem #6.

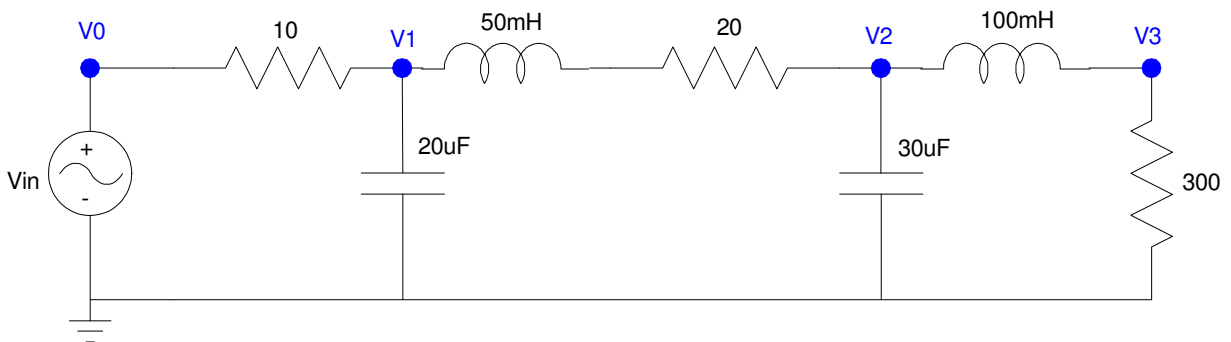

Problem, 6 & 7