

---

**ECE 111: Intro to ECE**  
**Lecture #16:**  
**ECE 311 Energy Conversion**  
**Jake Glower**

Please visit [Bison Academy](#) for corresponding  
lecture notes, homework sets, and solutions

---

---

## Objective of Today's Lecture:

- Transformer Operation
- Efficiency of a power grid
- Why we use AC instead of DC
- Why there are transformers & substations.



---

# Magnetism and Current

Current and magnetism are inherently related

$$B = \frac{\mu I}{2\pi r} \quad \text{magnetic field strength}$$

Changing magnetic fields produce voltage (Faraday's Law)

$$V = N \frac{d\phi}{dt}$$

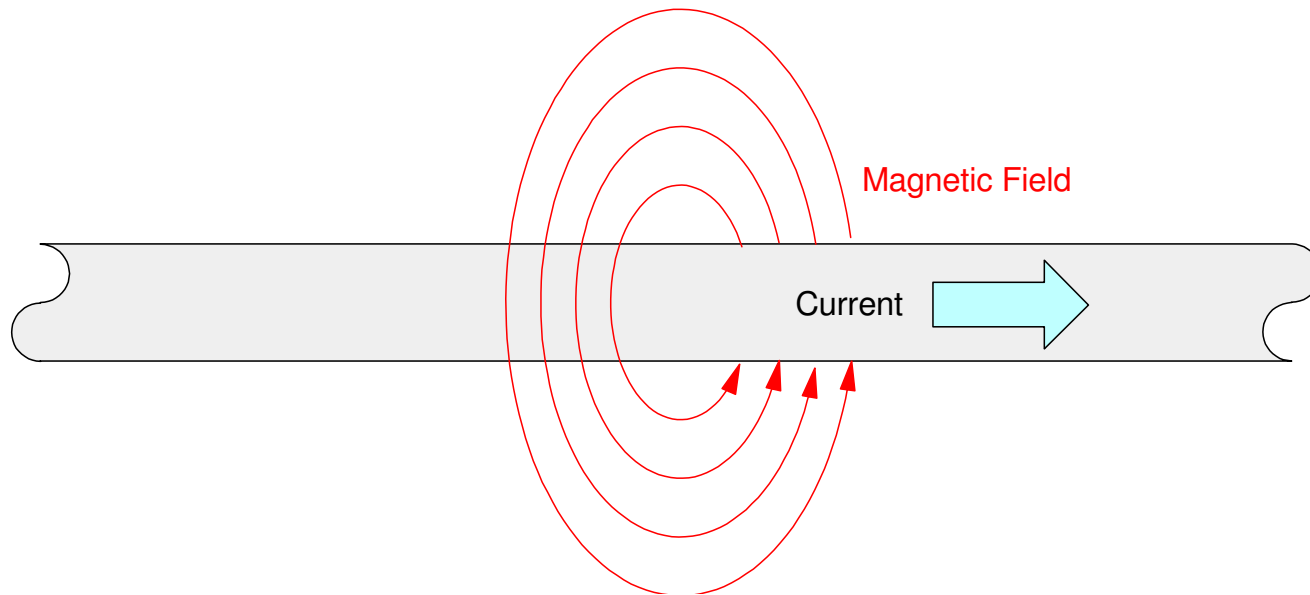

# Transformers

- If you apply current to a coil, you produce magnetic flux ( think of it as magnetic current )
- If you have a changing magnetic flux flowing through a coil, you produce current

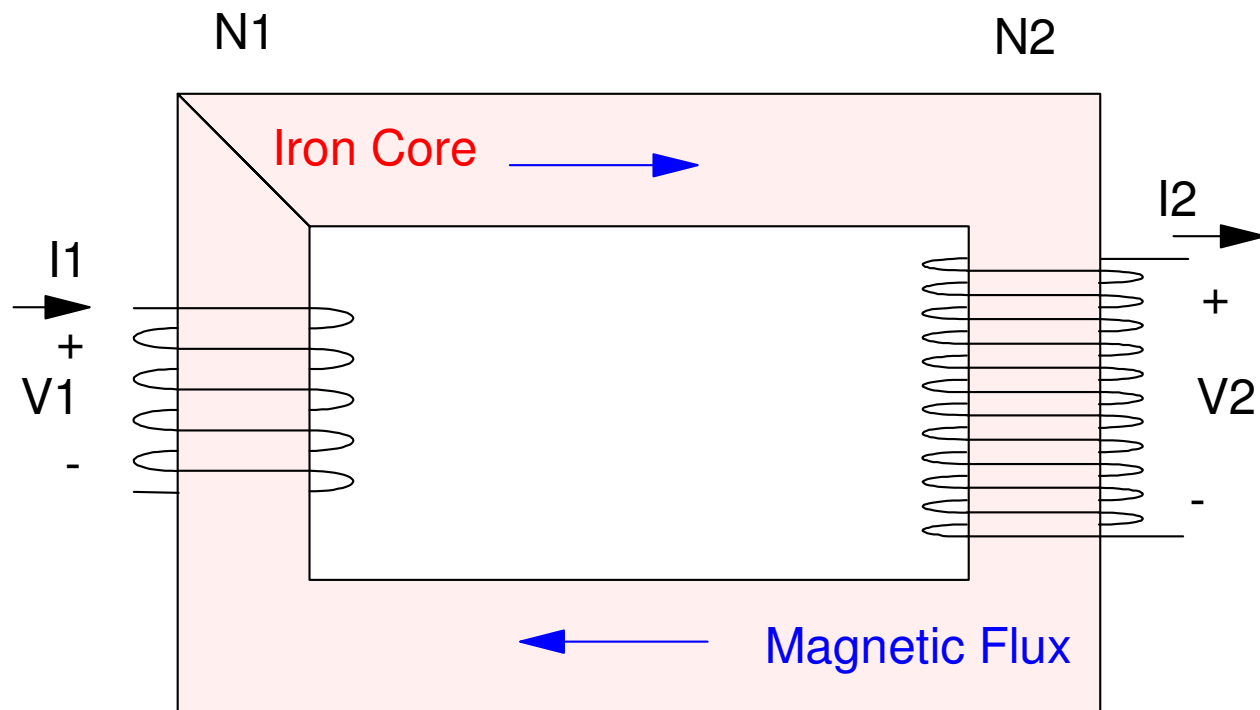

# Transformer Equations

Flux Created

$$\phi = N_1 I_1 \quad \text{amp-turns}$$

Conservation of flux:

$$\phi = N_1 I_1 = N_2 I_2$$

meaning

$$I_2 = \left( \frac{N_1}{N_2} \right) I_1$$

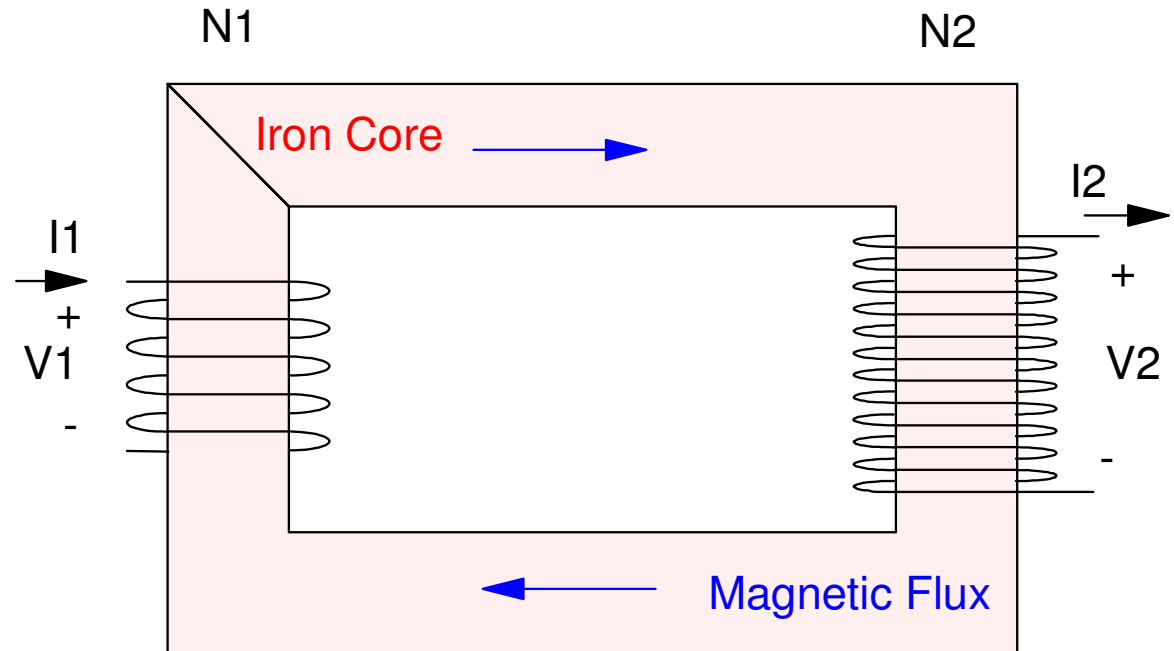

## Conservation of energy

$$V_1 I_1 = V_2 I_2$$

Substituting:

$$V_2 = \left( \frac{N_2}{N_1} \right) V_1$$

**Transformers convert one voltage to another by the turns-ratio**

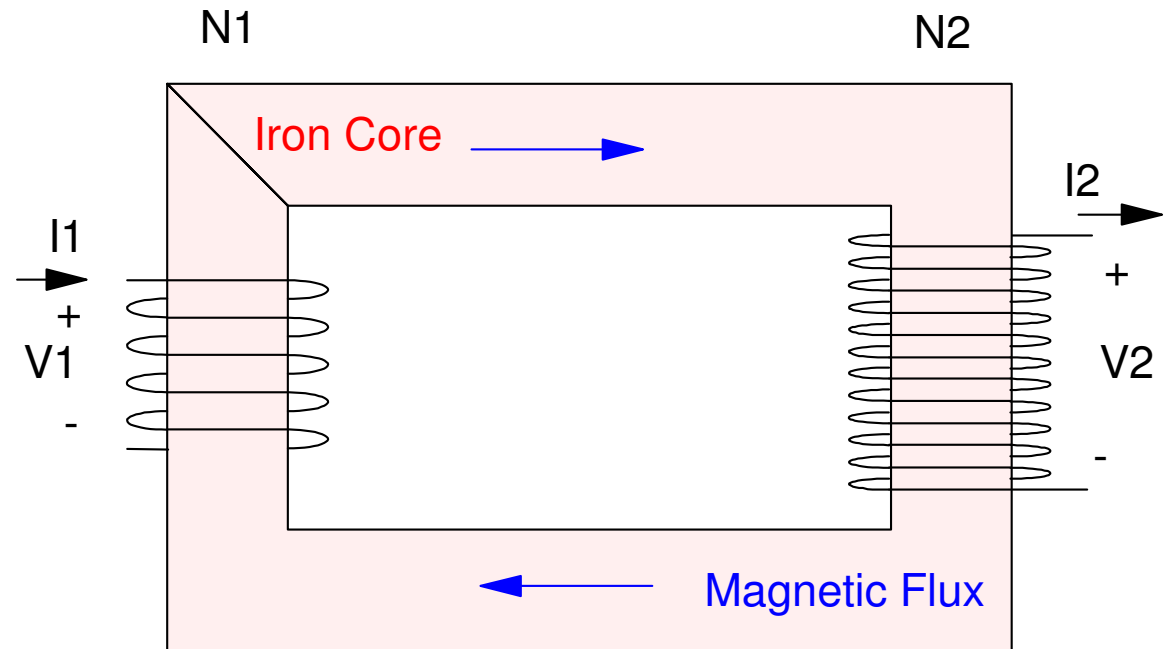

---

# Impedances & Transformers

If you connect an impedance to side 2 of the transformer, the impedance on side 2 by definition is

$$Z_2 = \frac{V_2}{I_2}$$

Transferring this to side one gives

$$Z_1 = \frac{V_1}{I_1} = \frac{\left(\frac{N_1}{N_2}\right) V_2}{\left(\frac{N_2}{N_1}\right) I_2} = \left(\frac{N_1}{N_2}\right)^2 \left(\frac{V_2}{I_2}\right)$$

$$Z_1 = \left(\frac{N_1}{N_2}\right)^2 Z_2$$

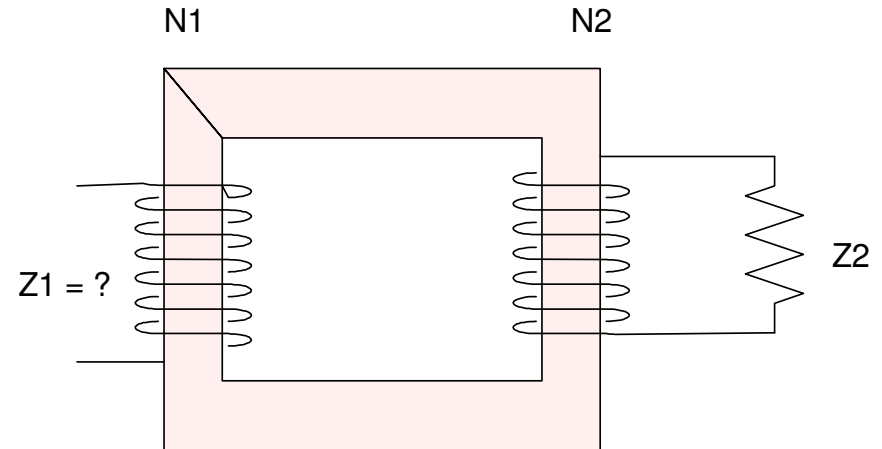

**Impedances seen through a transformer scale by the square of the turns ratio**

---

---

## Applications (take 1)

Drive an 8 Ohm speaker

$$V_L = \left( \frac{8}{100+8} \right) V_{in}$$

Only 7.4% of the voltage gets to the speaker

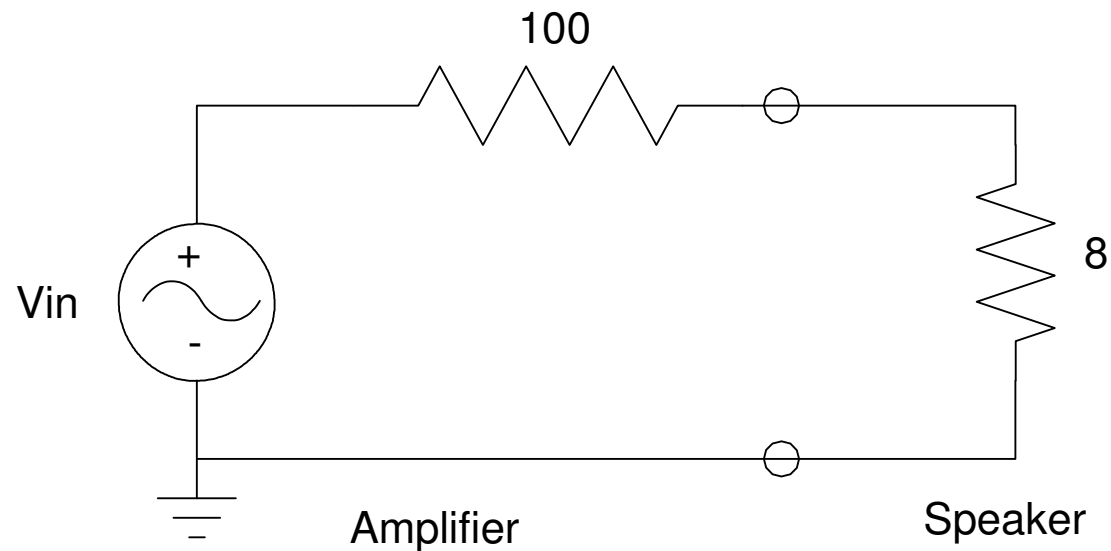



---

## Add a Transformer:

The amplifier sees an 800 Ohm resistor

- Impedance increases as the square of the turns ratio

Now, 89% of the power goes to the speaker

- But you have 10x the voltage on the amplifier side

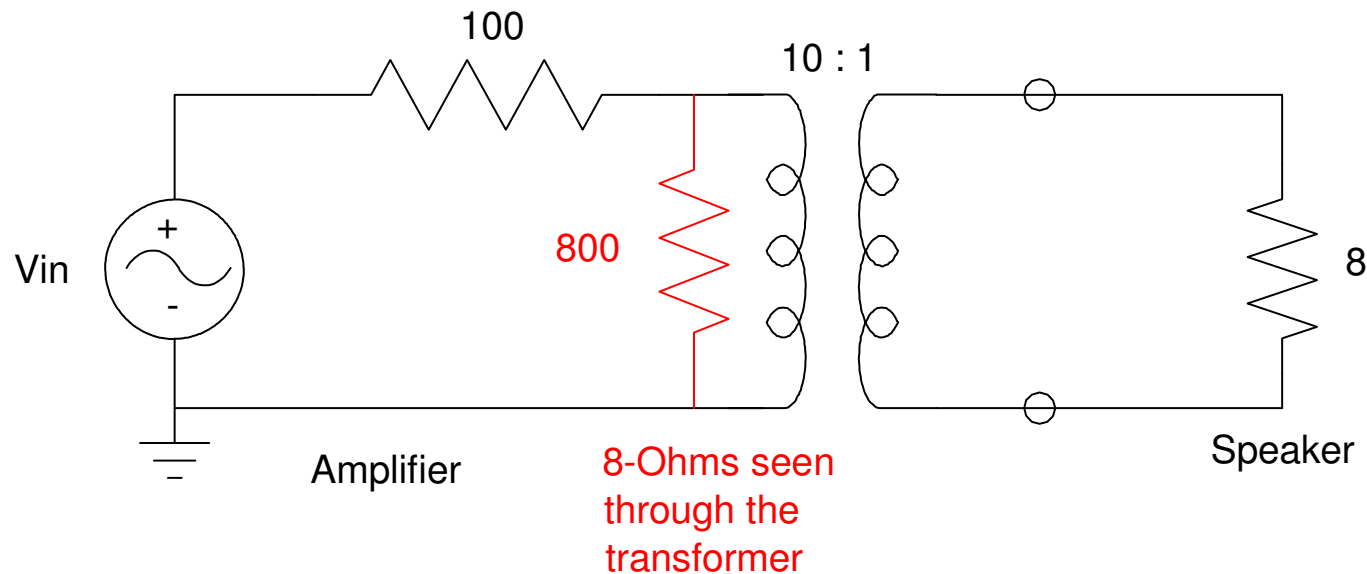

---

## Handout:

- Redraw the circuit as seen by the load (transfer everything to the right side of the transformer)
- Determine the voltages and current as seen by the load

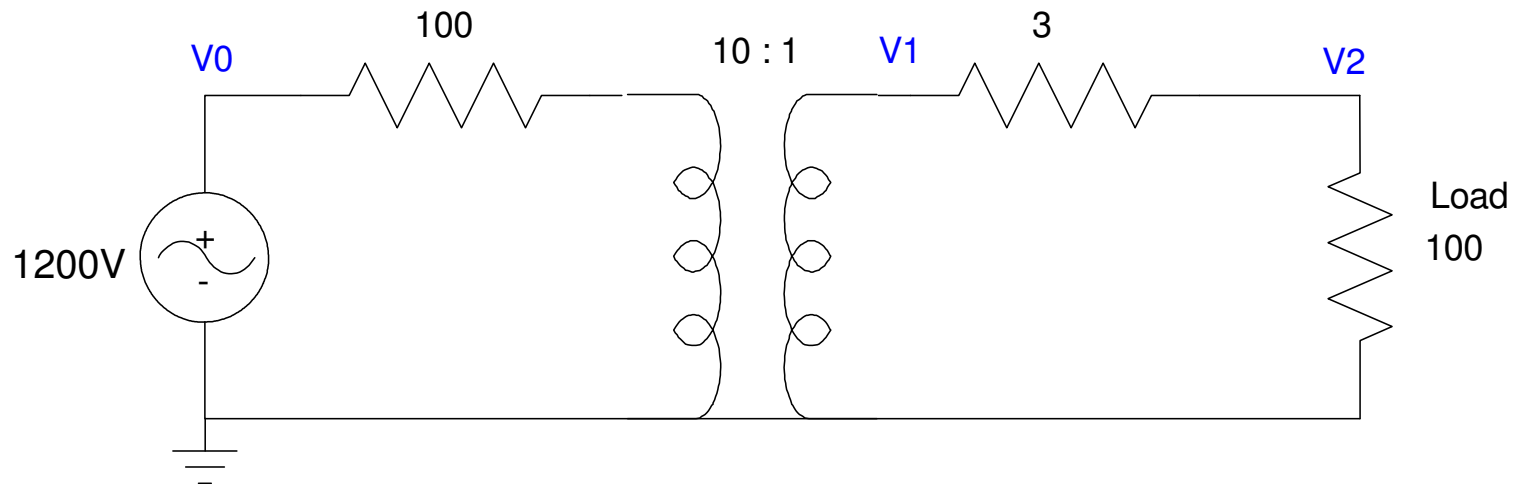

---

# Transformer Construction

An iron core is used to carry the magnetic flux

- Iron is 8,000 to 100,000 times more magnetic than air
- This makes transformers heavy

The core is

- Split to reduce Eddy currents
- Laminated to further reduce Eddy currents

You still have some losses in the core

- Transformers get warm when energized
- This is modeled as a resistance (lossy element)

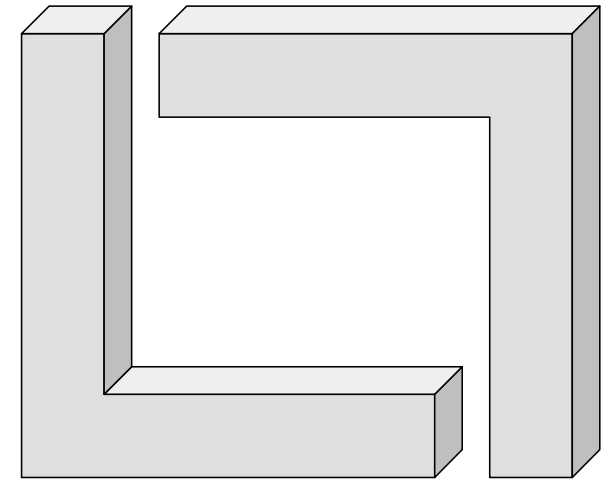

Front View

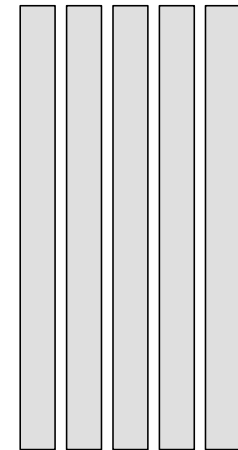

Side View

---

---

# Transformer Modeling

Assume 60Hz:

- Core Model: Inductance of the transformer ( $jX_c$ ) & transformer losses ( $R_c$ )
- Line Model: Inductance of the wires ( $jX_L$ ) & copper losses ( $R_L$ )

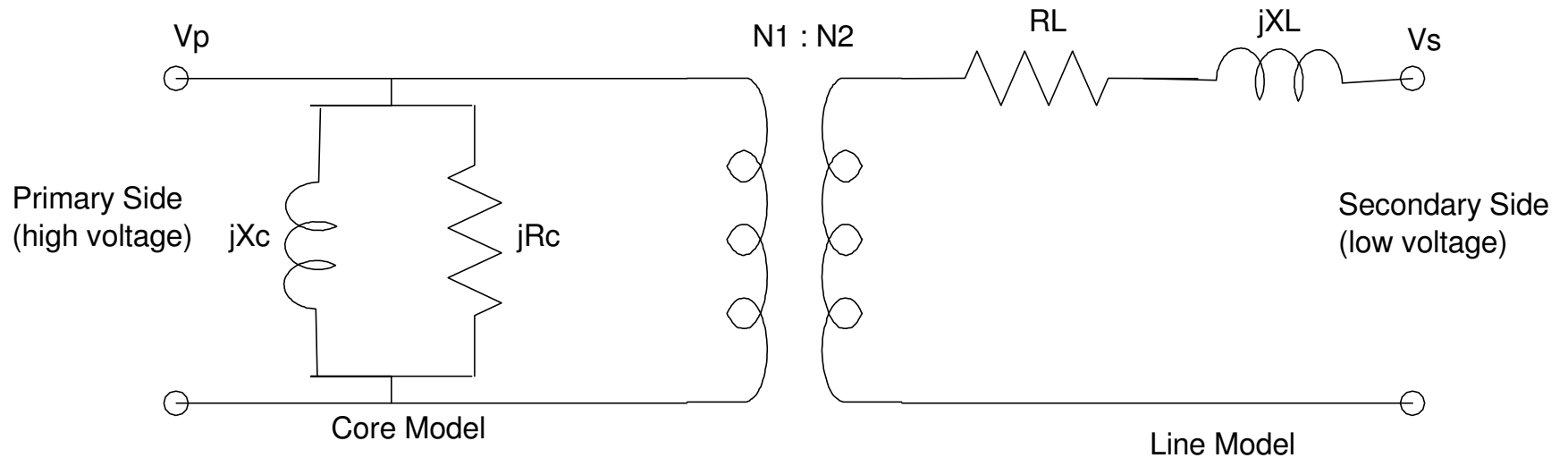

---

## Power Factor

Often times in power systems, a parameter called *power factor* is used:

$$\text{Power Factor} = \frac{\text{real(power)}}{\text{abs(V)} \cdot \text{abs(I)}} = \cos \theta$$

where

$$R + jX = Z \angle \theta$$

Power is

$$P = \frac{V^2}{Z} \cdot pf = |V| \cdot |I| \cdot pf$$

The impedance as a function of power and power factor is:

$$Z = \left( \frac{V^2 \cdot pf}{P} \right) \angle \arccos(pf)$$

---

---

# Transformer Testing

Open Circuit Test: ( This measures  $R_c$  and  $jX_c$  )

- Leave the secondary side open.
- Apply rated voltage to the primary side and measure the voltage, current, and power.

Short Circuit Test: ( This measures  $R_1$  and  $jX_1$  )

- Short the primary side.

Example: A 13kV : 240V transformer

	V	Power	pf
Open-Circuit Test	$V_p = 13\text{kV}$	100 W	0.02
Short-Circuit Test	$V_s = 10\text{V}$	200 W	0.95

---

# Open-Circuit Test:

- Secondary side = open  
current = 0  
RL & jXL don't matter
- $V_p = 13.2kV$
- $P = 100W$
- $pf = 0.02$
- Find the core model ( $R_c$  &  $jX_c$ )

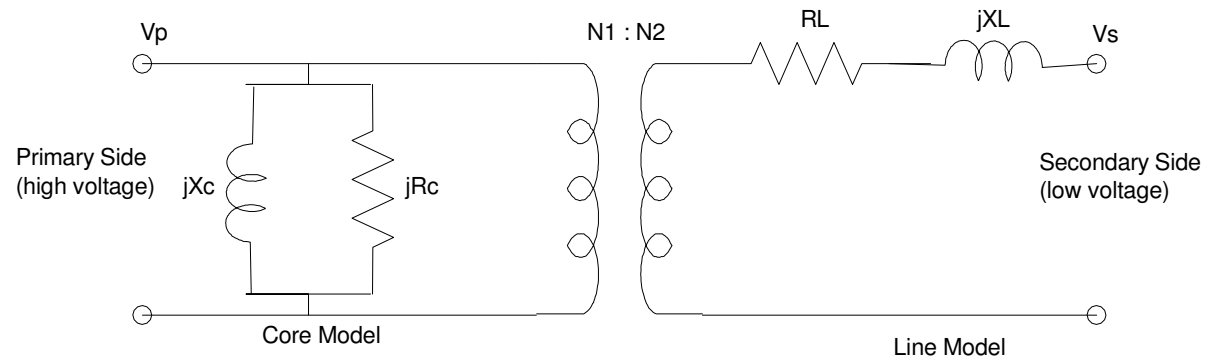

$$P = |V| \cdot |I| \cdot pf$$

$$100W = 13.2kV \cdot |I| \cdot 0.02$$

$$|I| = 0.3788A$$

## Open-Circuit Test (cont'd)

$$Z = \left( \frac{|V|}{|I|} \right) \angle \arccos(pf)$$

$$Z = \left( \frac{13.2kV}{03788A} \right) \angle \arccos(0.02)$$

$$Z = 34,848 \angle 88.854^\circ$$

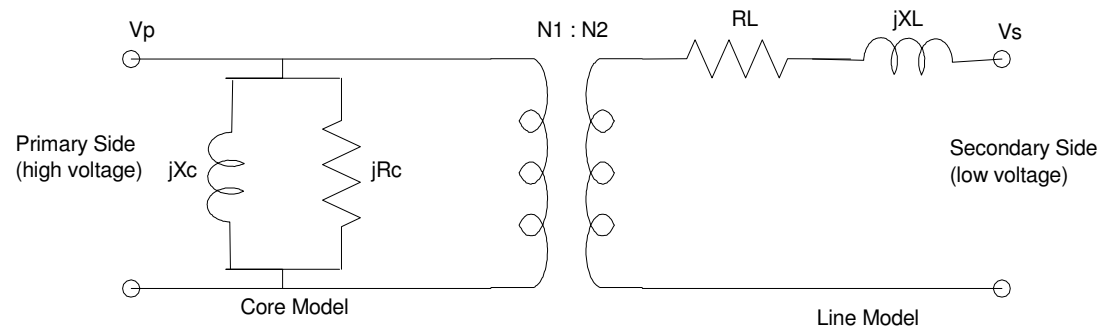

$$Z = 696.96 + j34,841.03$$

*series model for R & L*

$$\frac{1}{Z} = \frac{1}{R_c} + \frac{1}{jX_c} = 5.739 \cdot 10^{-7} - j2.869 \cdot 10^{-5}$$

$$R_c = \frac{1}{5.739 \cdot 10^{-7}} = 1.742M\Omega$$

*parallel model for R & L*

$$jX_c = \frac{1}{-j2.869 \cdot 10^{-5}} = j34.854k\Omega$$



# Short Circuit Test:

- $V_p = 0V$  (short)  
 $R_c \text{ \& } jX_c = 0 \text{ Ohms (shorted)}$
- $V_s = 10V$
- $P = 200W$
- $pf = 0.95$
- Find  $R_L$  &  $jX_L$

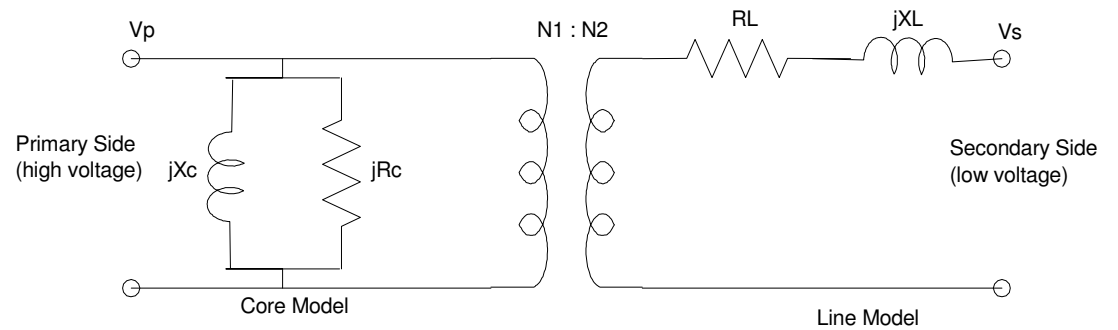

$$P = |V| \cdot |I| \cdot pf$$

$$200W = 10V \cdot |I| \cdot 0.95$$

$$|I| = 21.053A$$

## Short Circuit Test (cont'd)

$$Z_L = \left( \frac{|V|}{|I|} \right) \angle \arccos(pf)$$

$$Z_L = \left( \frac{10V}{21.053A} \right) \angle \arccos(0.95)$$

$$Z_L = 0.4750 \angle 18.19^\circ$$

$$Z_L = 0.4513 + j0.1483$$

$$R_L = 0.4513\Omega \quad jX_L = j0.1483\Omega$$

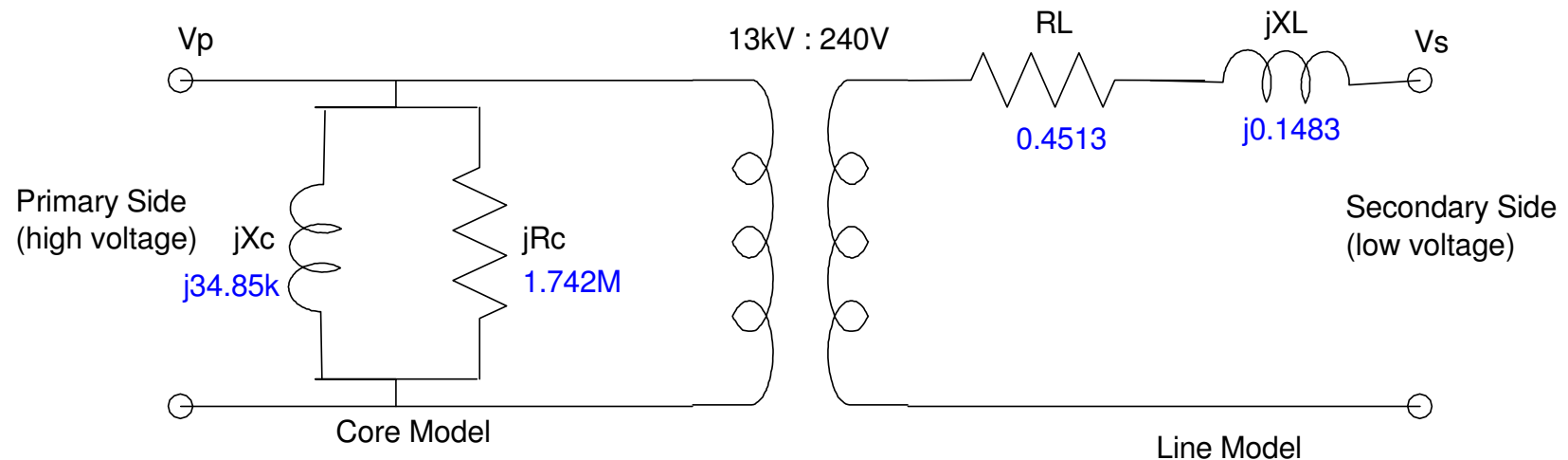

---

## Handout:

Determine the series ( $R_s$ ,  $jX_s$ ) and parallel ( $R_p$ ,  $jX_p$ ) model for the load ( $Z$ )

- $V_{in} = 9600V$
- Power = 200 Watts
- $pf = 0.05$

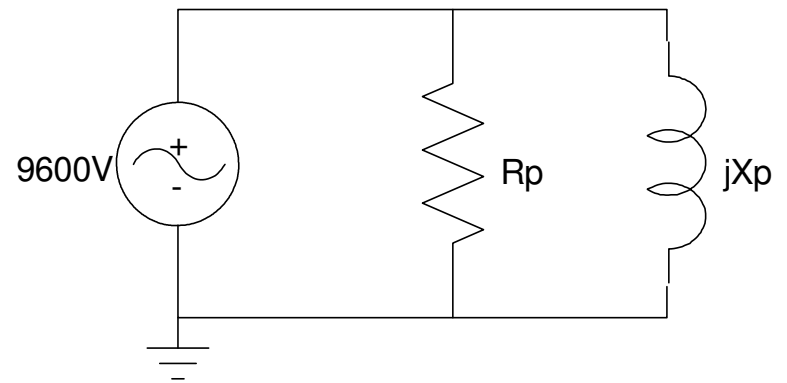
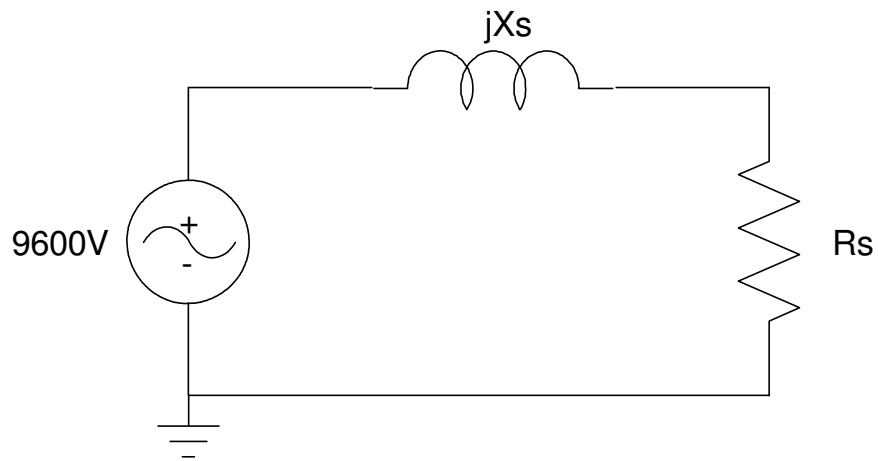

---

## Transmission Line Analysis:

In 2021, North Dakota produced 3908 GWh of electricity:

- U.S. Energy and Information Administration
- At \$0.10/kWh, this equates to \$398 million.
- A large percentage of this energy is transmitted east to Minneapolis and Chicago.

Source	GWh	% of Total
Gas	73	2%
Hydro	222	6%
Wind / Solar	1,645	42%
Coal	1,968	50%
<b>Total</b>	<b>3,908</b>	<b>100%</b>

---

---

## Problem:

How do you transmit large amounts of energy over a distance of 1000km (Minneapolis) or 2000km (Chicago)?

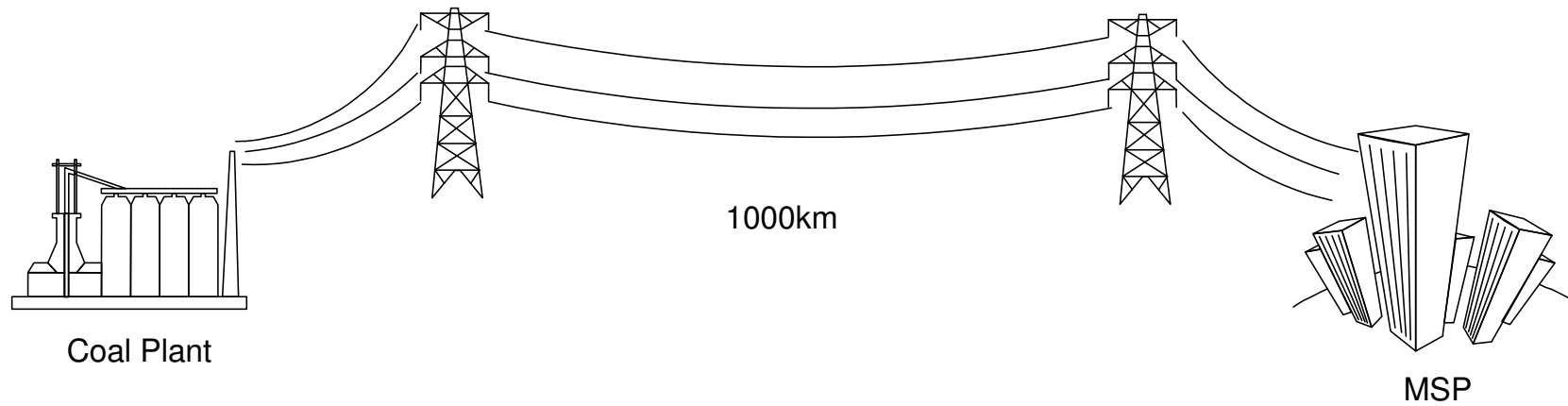

# How much power does a home use?

## Case Study: My house

- 2000 square feet
- 5400W solar panels on roof
- August 5, 2022 (93F day)
- About 3kW (worst case)

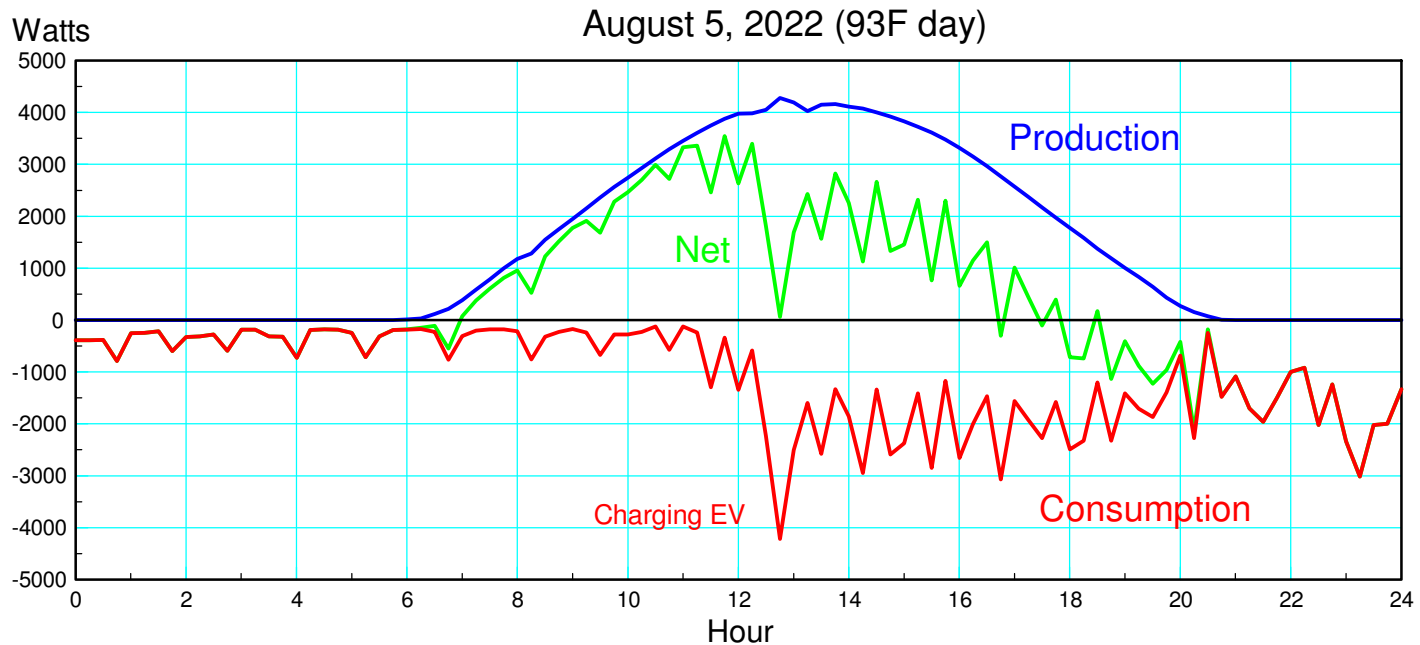

# Option 1: DC Power Grid

## Thomas Edison's vision

- Produce and transmit DC power
- Place dynamos (DC generator) every 2-3 miles

## What happens if you try to transmit power 1000km?

- 1000km of 1cm dia aluminum wire = 14.36 Ohms

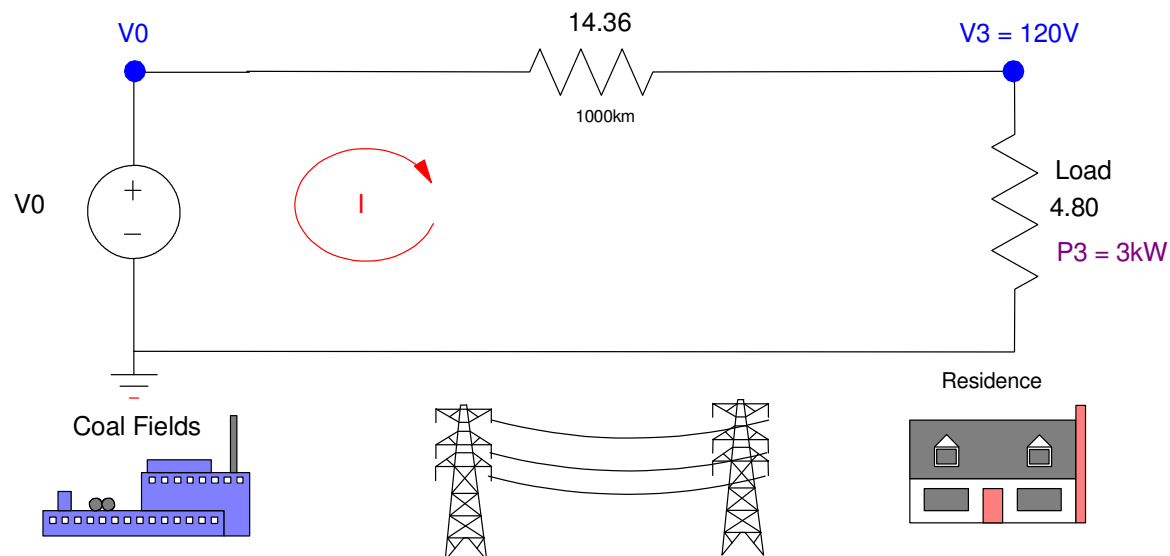

# DC Power Grid Analysis: 1 Customer

Each customer = 3kW

$$I = \frac{3kW}{120V} = 25A$$

Transmission Line Losses:

$$P_{03} = I^2 R = (25A)^2 \cdot 14.36\Omega$$

$$P_{03} = 8795W$$

Efficiency

$$\eta = \frac{\text{power to load}}{\text{total power}} = \frac{3kW}{3kW+8795W} = 25.4\%$$

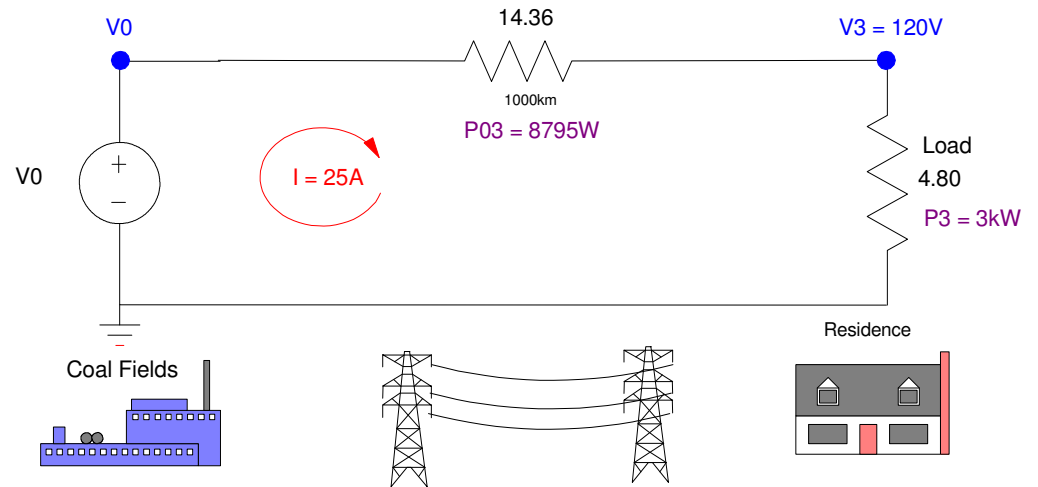



# DC Power Grid Analysis: N Customers

- Power to load increases by N
- Line losses increase by  $N^2$

Efficiency

$$\eta = \left( \frac{3kW \cdot N}{3kW \cdot N + 8795 \cdot N^2} \right) \cdot \left( \frac{1/N}{1/N} \right)$$

$$\eta = \left( \frac{3kW}{3kW + 8795 \cdot N} \right)$$

The efficiency gets worse as you add customers

A 120V DC power grid would require generators every 2-3 miles

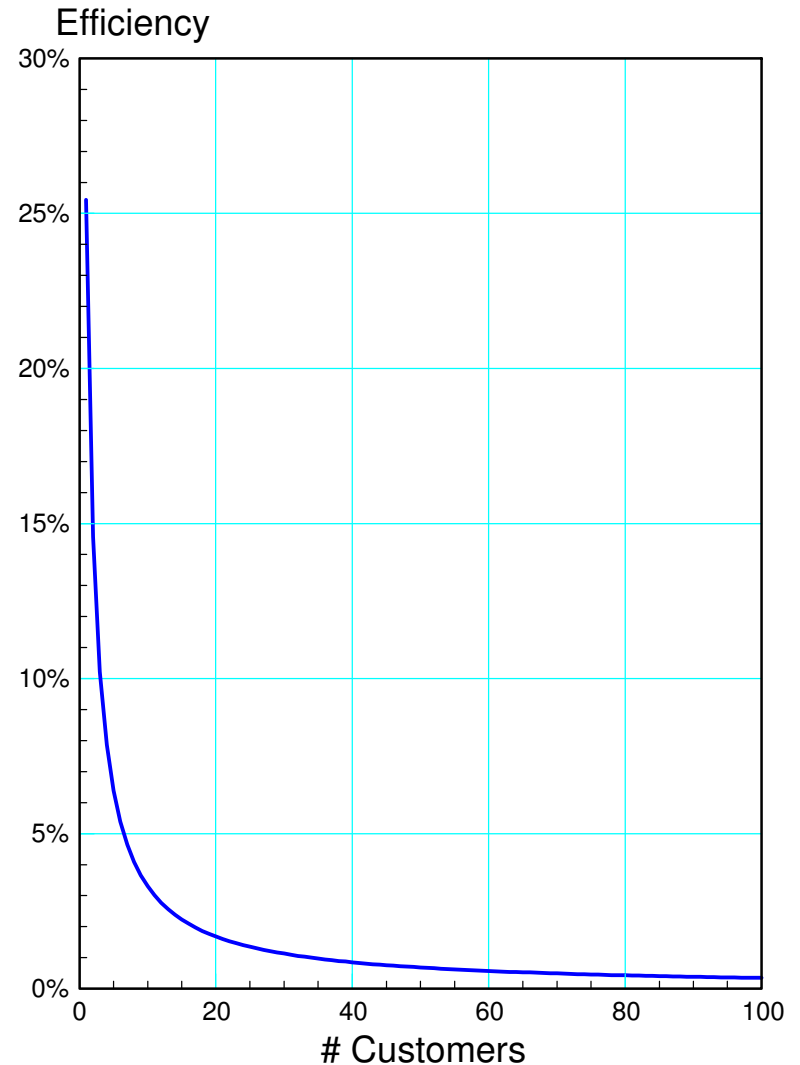

# Option 2: AC Power Grid

## Tesla's vision

- Bump up the voltage to 345kV at the coal plant
- Step down to 13.2kV at a substation near the city, and then
- Stepped down to 120V close to the residence:

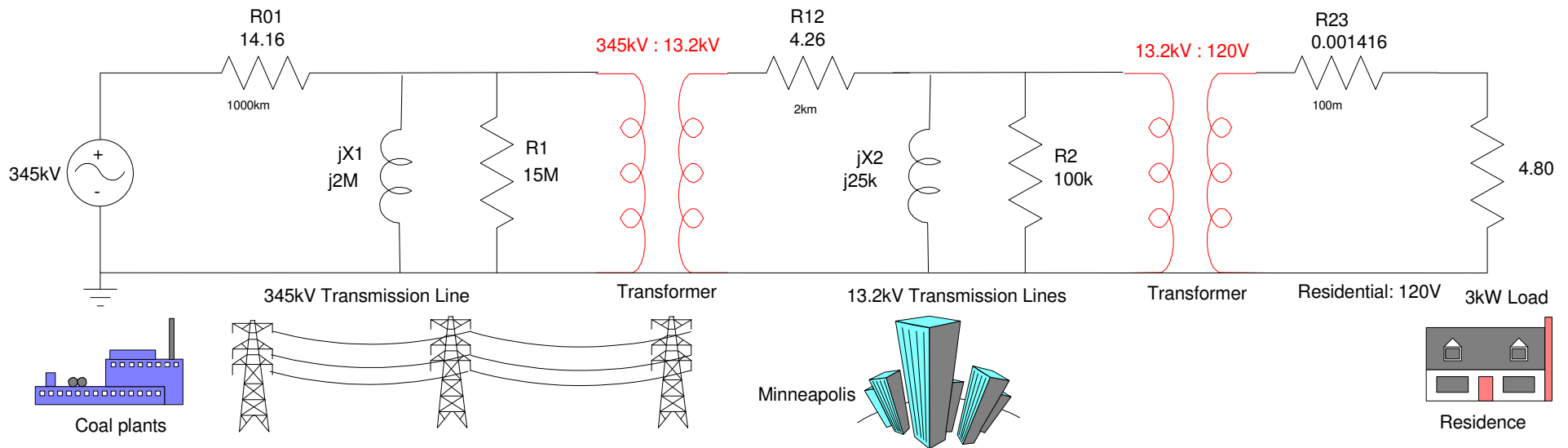

# Analysis of AC Power Grid

Step 1: Remove the transformers

$$V_2 = \left(\frac{N_2}{N_1}\right) V_1$$

$$Z_2 = \left(\frac{N_2}{N_1}\right)^2 Z_1$$

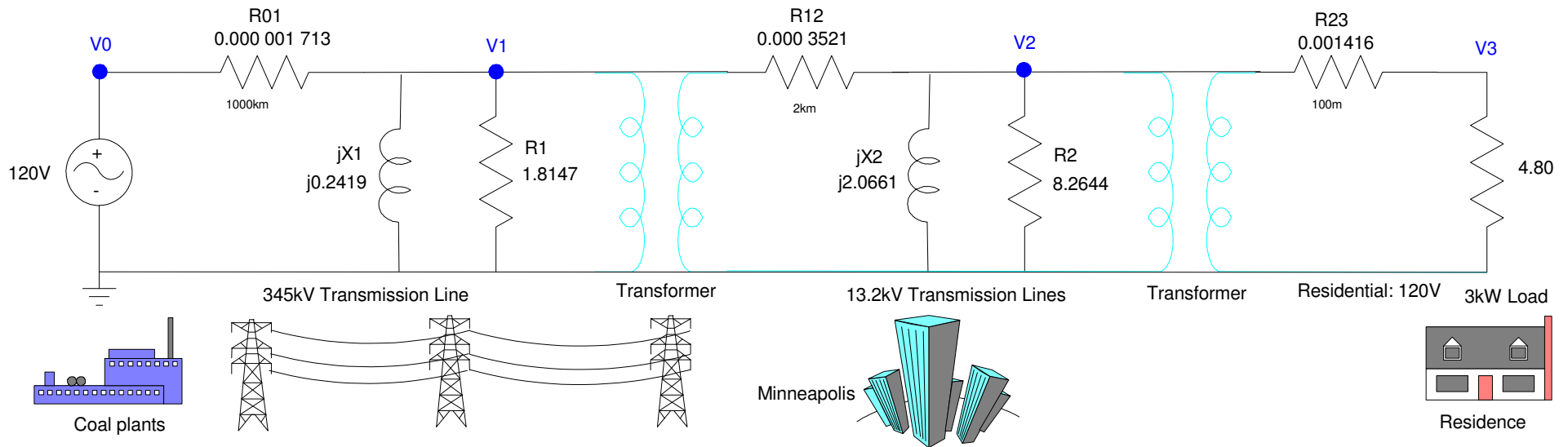

## Step 2: Write the voltage node equations:

$$\left(\frac{V_1 - V_0}{R_{01}}\right) + \left(\frac{V_1}{jX_1}\right) + \left(\frac{V_1}{R_1}\right) + \left(\frac{V_1 - V_2}{R_{12}}\right) = 0$$

$$\left(\frac{V_2 - V_1}{R_{12}}\right) + \left(\frac{V_2}{jX_2}\right) + \left(\frac{V_2}{R_2}\right) + \left(\frac{V_2 - V_3}{R_{23}}\right) = 0$$

$$\left(\frac{V_3 - V_2}{R_{23}}\right) + \left(\frac{V_3}{R_3}\right) = 0$$

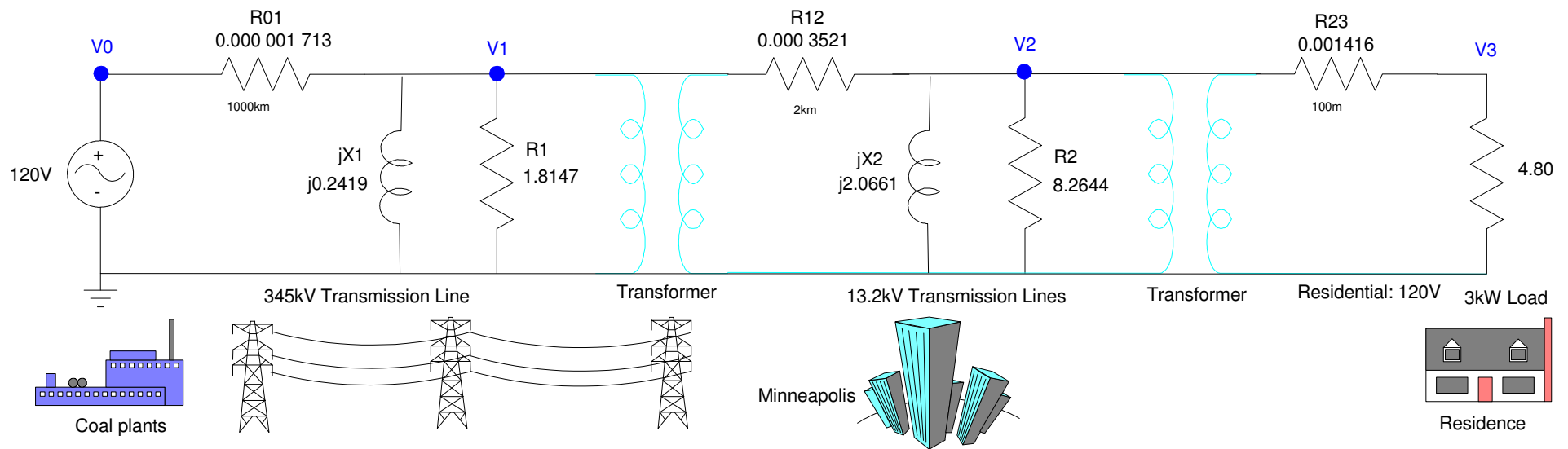

---

### Step 3: Place in matrix form and solve in Matlab.

```
>> a1 = [1,0,0,0];
>> a2 = [-1/R01, 1/R01+1/R1+1/(j*X1)+1/R12, -1/R12, 0];
>> a3 = [0,-1/R12, 1/R12+1/R2+1/(j*X2)+1/R23,-1/R23];
>> a4 = [0,0,-1/R23,1/R23+1/R3];
>> A = [a1;a2;a3;a4]
>> B = [120;0;0;0]
>> V = inv(A)*B
```

```
V0 120.000
V1 119.999 + 0.0094i
V2 119.985 + 0.2139i
V3 119.950 + 0.2138i
```

### Note: The voltage at the customer has drooped

- On hot days with high demand, the last customer's voltage can drop down to 110V
  - The utility can adjust the voltage output from the residential transformer to compensate
-

## Step 4: Calculate the power dissipated in each resistor

```
>> V0 = V(1);  
>> V1 = V(2);  
>> V2 = V(3);  
>> V3 = V(4);  
>> P01 = abs(V0 - V1)^2 / R01  
>> P1 = abs(V1)^2 / R1  
>> P12 = abs(V1 - V2)^2 / R12  
>> P2 = abs(V2)^2 / R2  
>> P23 = abs(V2 - V3)^2 / R23  
>> P3 = abs(V3)^2 / R3
```

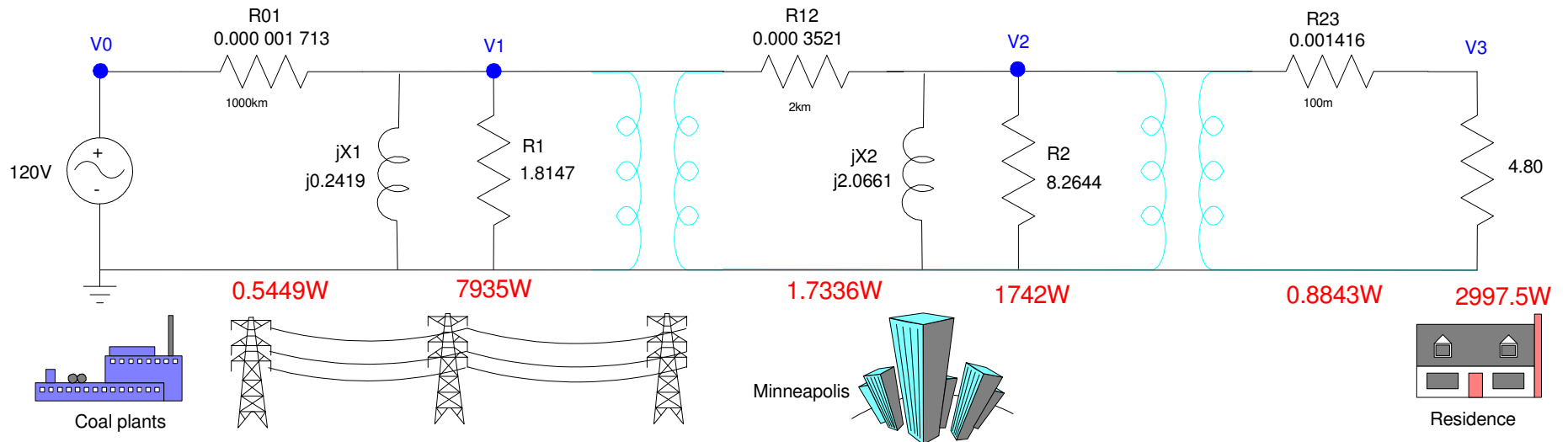

# Step 5: Efficiency of AC system with one customer

- Include the core losses
- Efficiency = 23.64%

```
>> eff = P3 / (P01 + P1 + P12 + P2 + P23 + P3)
    eff = 0.2364
```

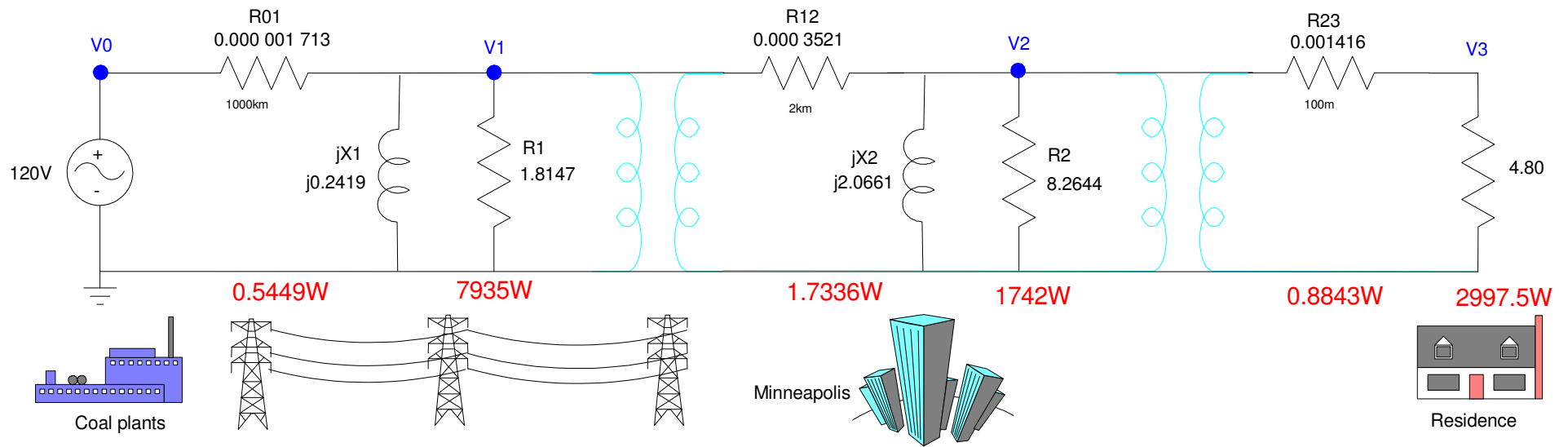

# Efficiency of AC System with N customers

- Per-customer basis
- Line losses scale by  $N$  ( $I^2R$ )
- Core losses scale by  $1/N$

```
eff = zeros(100,1);  
for N=1:100  
    eff(N) = P3 /  
        (P3+ (P01+P12+P23) *N+ (P1+P2) /N) ;  
end  
plot (eff)
```

Efficiency approaches 90%

Efficiency drops off slightly with demand

- Hot summer days
- Cold winter days
- 6pm (peak demand)

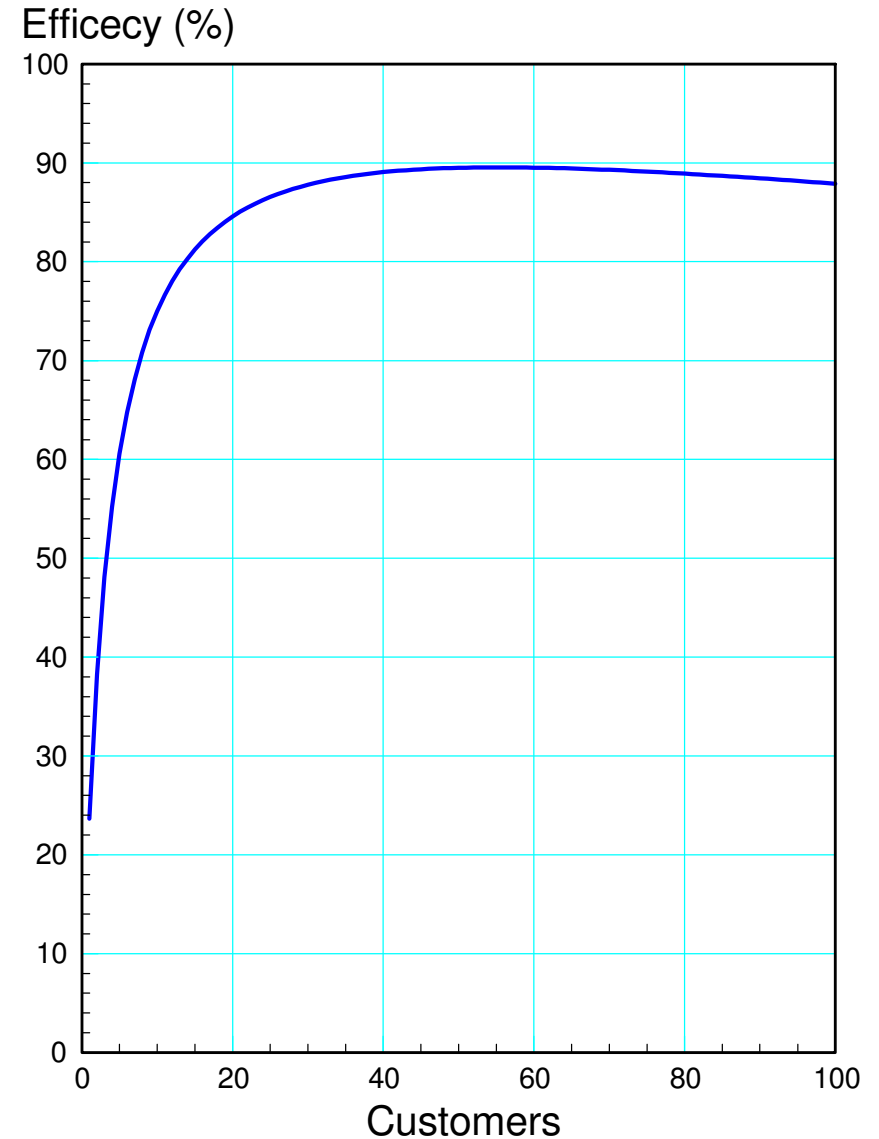



# Efficiency of AC system with many customers

- Approximate
- Ignore core losses (they are shared by a large number of customers)

$$\gg \text{eff} = P_3 / (P_{01} + P_{12} + P_{23} + P_3)$$
$$\text{eff} = 0.9989$$

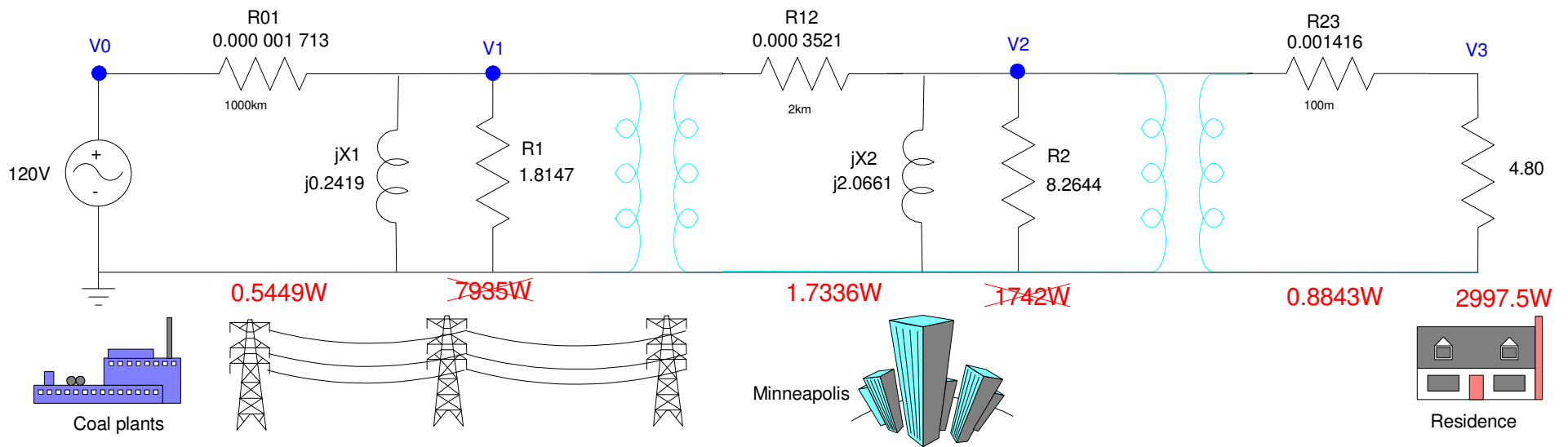

---

## Conclusion

Our power grid runs at 60Hz (AC)

- DC power grid (Edison's plan) limits transmission lines to about 2 miles
- AC power grids (Tesla's plan) allows longer transmission lines

The power grid is actually really efficient.

- 80% to 90% efficient under normal operating conditions

It is impractical for a utility to run a power line to a single customer.

- It's more efficient to have that customer run a diesel generator for really remote locations.

It costs the utility money even if the customers are not using any power.

- It takes energy (and money) to keep the grid powered up.
-

## Note #1: This is why we have high-voltage transmission lines

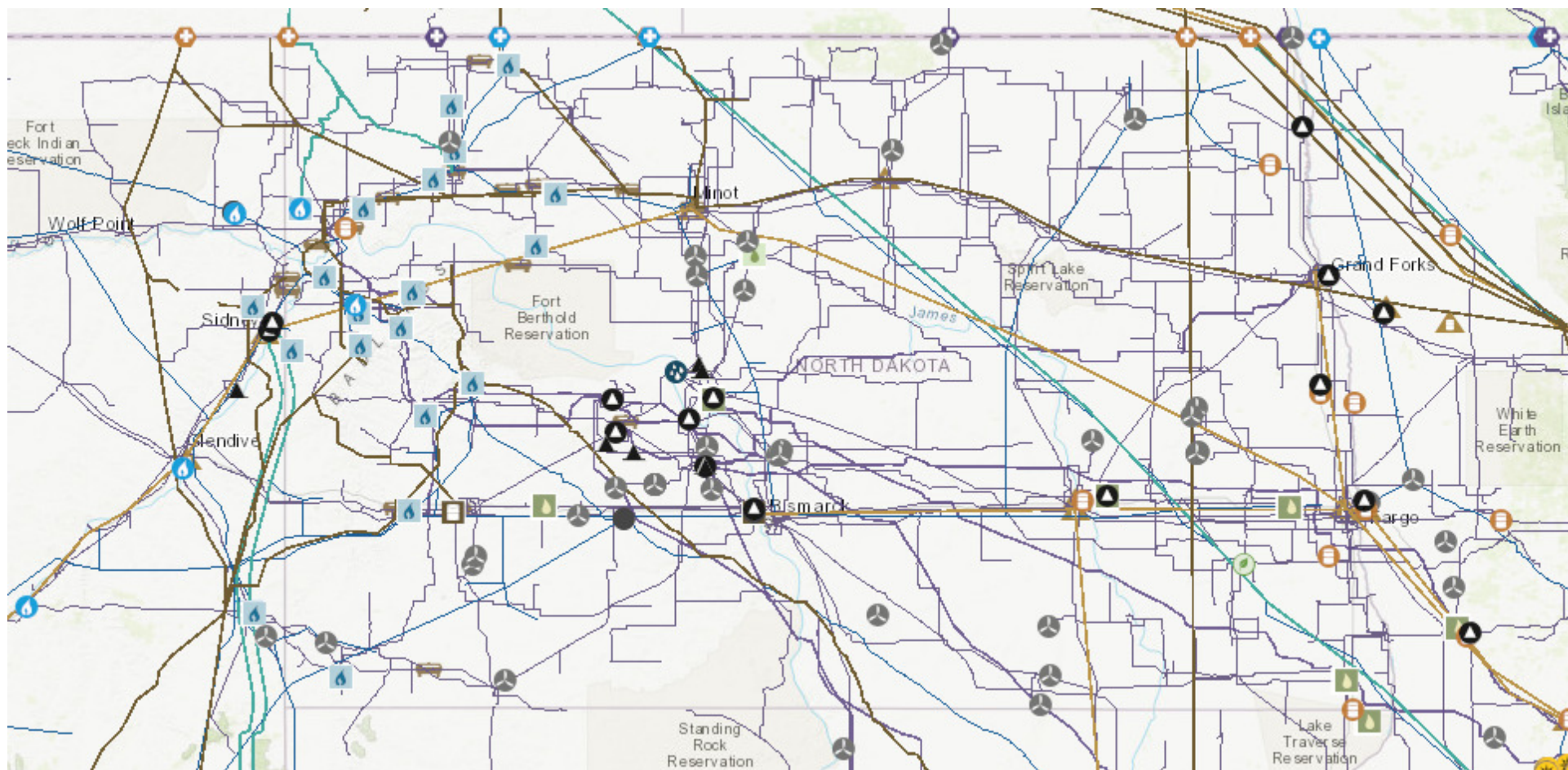

Power plants and transmission lines (345kV or more) in North Dakota. Source: <http://www.eia.gov/state/?sid=ND>

## Note #2: Wind Energy is Inexpensive

- It's hard to compete with an energy source where the fuel cost is \$0
- This is why so many wind farms are being built in North Dakota, South Dakota, Minnesota, etc.

- Wind 1.34 cents / kWh
- Nuclear<sup>1</sup> 2.438 cents / kWh
- Coal/Steam<sup>1</sup> 3.088 cents / kWh
- Solar 4.08 cents / kWh
- Gas<sup>1</sup> 6.44 cents / kWh
- Hydro<sup>1</sup> 9.32 cents / kWh
- Coal w/ CCS<sup>1</sup> 25 - 32 cents / kWh

(1) U.S. Energy and Information Administration

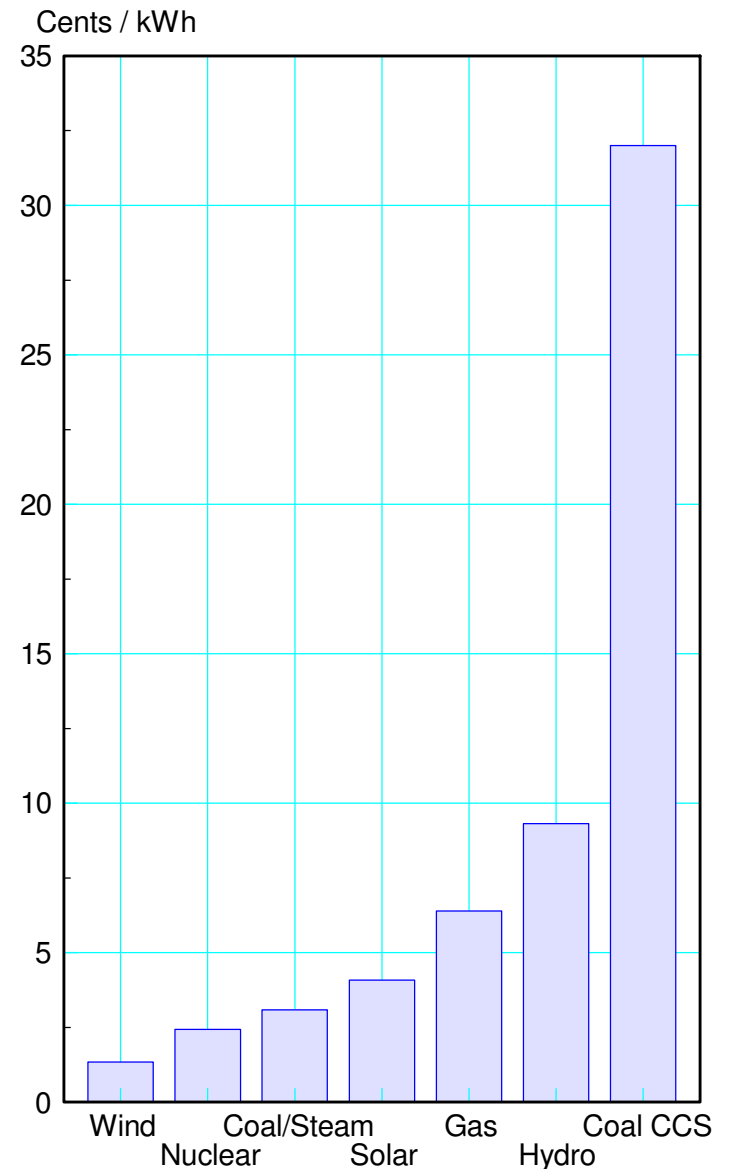

---

## Note #3: Wind Energy Benefits Farmers

NDSU study reported in [www.Sciencing.com](http://www.Sciencing.com)

### Wind Rights:

- \$2,000 to \$10,000 / acre
- Paid to the farmer
- 20-year lease typical

### Production Royalties

- \$4,000 to \$6,000 per MW per year

### Example: 2MW wind turbine

- \$100,000 up front (wind rights)
- \$10,000/year (production royalties)
- Plus, you can keep using the land

photo: <https://thumbs.dreamstime.com/b/cow-wind-turbine-12454919.jpg>



## Note #4: North Dakota is windy

- North Dakota has enough wind to produce 1.182TWh of electricity each year

National Renewable Energy Administration  
<https://www.nrel.gov/docs/fy00osti/28054.pdf>

- Enough to supply 25% of the nation's electricity needs
- Enough to produce \$118 billion in revenue each year at \$0.10 / kWh
- Enough to double the state's GDP  
<http://www.deptofnumbers.com/gdp/north-dakota/>

To do this, we'll need more high-voltage transmission lines to get this energy out of the state

