Circuits I

ECE 111 Introduction to ECE

Jake Glower - Week #8

Please visit [Bison Academy](#) for corresponding
lecture notes, homework sets, and solutions

Circuits I

Circuits I is the first course you take in ECE which covers the analysis of electrical circuits. In the first half of Circuits I, we cover DC analysis circuits with

- Voltage sources,
- Current sources, and
- Resistors.

For example, a typical circuit would be:

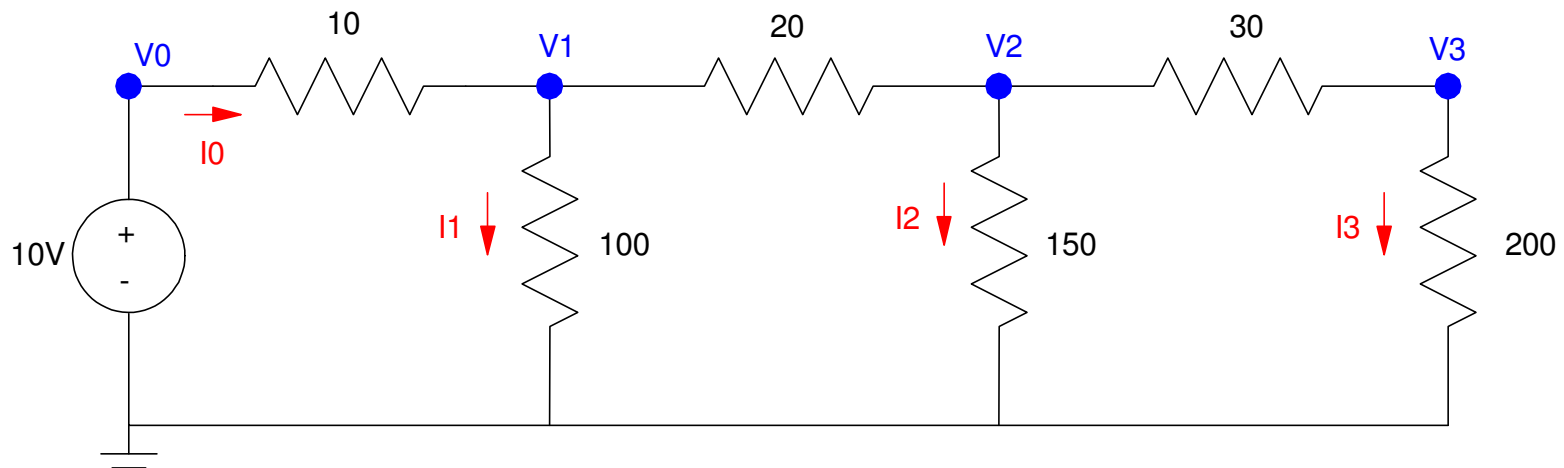

Typical problem in Circuits I: Determine the voltages and currents

Definitions

Protons: Part of the nucleus of an atom.

- Protons do not move.

Electrons: Part particle, part wave.

- Negatively charge particles which do move (and carry current)

Current: The flow of electrons.

- $1\text{A} = 1.602 * 10^{19}$ electrons per second.

Voltage: The force that causes current to flow.

- The energy released when current flows.
- 1 Amp of current flowing across 1 Volt produces 1 Joule.

Resistance: The resistance to current flow.

- $V = I R$
 - 1 Volt = 1 Amp flowing across 1 Ohm
-

Water Analogy

- The pressure (or distance) the water flows downhill corresponds to voltage
- The actual flow of water corresponds to current
- The pipe which limits the flow of the water is resistance.

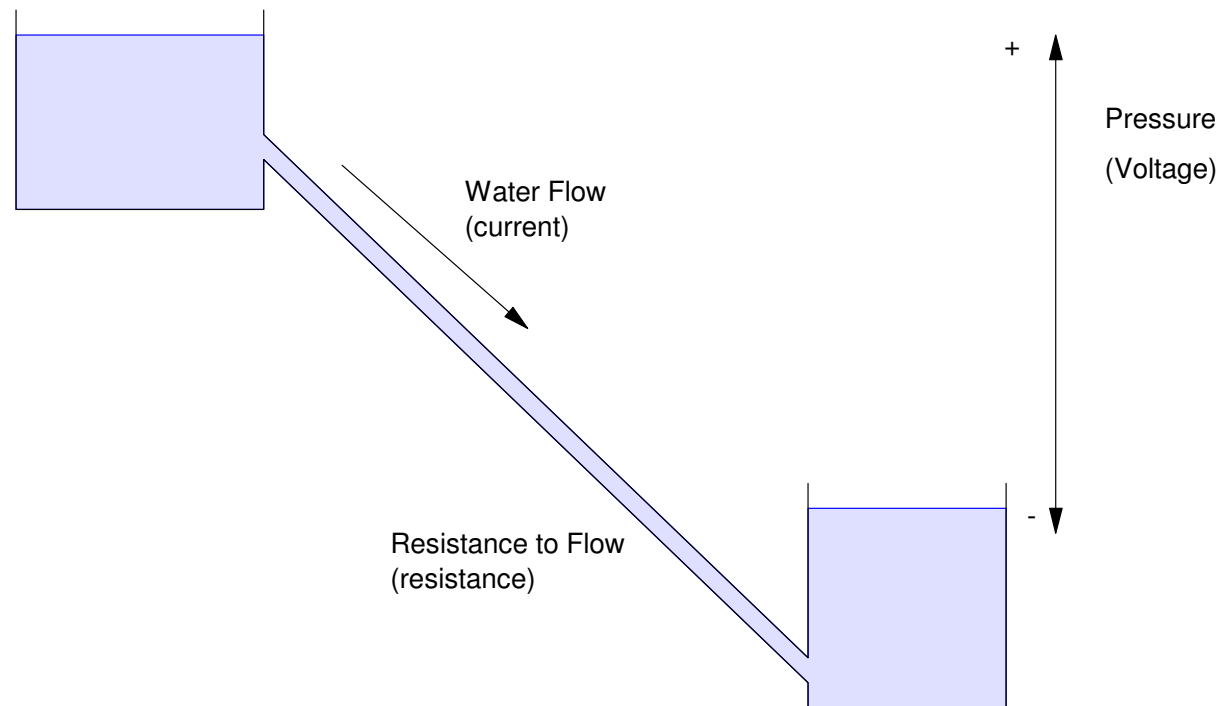

Voltage Source

- Basic circuit element
- Provides a constant voltage across terminals
- Think car battery

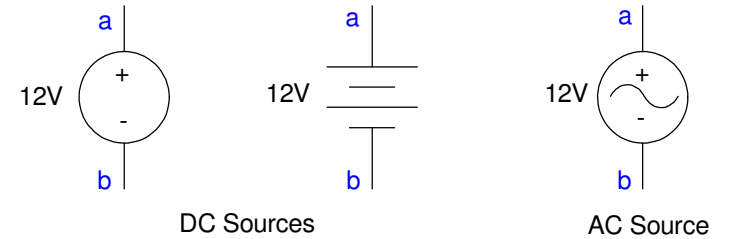

Voltage	Example	Enough voltage to...
1.5V	AA battery	Turn on a single LED
5.0V	USB Battery	Power a computer
13.2V	Car battery	Turn a motor (starter)
120V	Wall Outlet	Power a computer, hair dryer
13,200V	Residential transmission lines	Power a residential subdivision Kill a person
345,000V	Long distance transmission lines	Power a small city Create an arc 11cm long

Current Source

A current source sets the current flowing in a circuit. These are used for

- LED lights: The current determines the light output.
- DC Motors: Current is torque

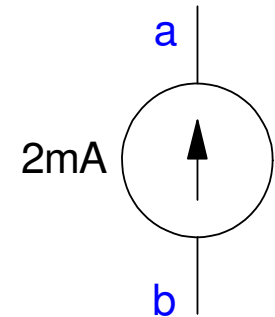

Current	Diameter of wire to carry.	Example
1 μ A 0.000 001A	0.000 7mm	Sleep mode for a TV remote
1mA 0.001A	0.021 mm	Power a single LED (dim)
1A	0.72mm	Charging a cell phone
10A	2.3mm	Hair dryer
100A	7.3mm	Welding

Watts

- Energy
- Energy must always balance (energy in = energy out)

Watts	Example
1mW	power-on indicator LED
1W	Human Heart
10W	1000 Lumen LED Light Bulb
100W	Bicycling (300W = Tour de France)
1kW	Max output of elite athletes Hair dryer
10kW	Lawn Tractor (15.6hp)

Resistors:

- Resistors turn current into heat.
- Limit current flow

Equations:

$$V = IR \quad \text{Volts}$$

$$P = VI = I^2R \quad \text{Watts}$$

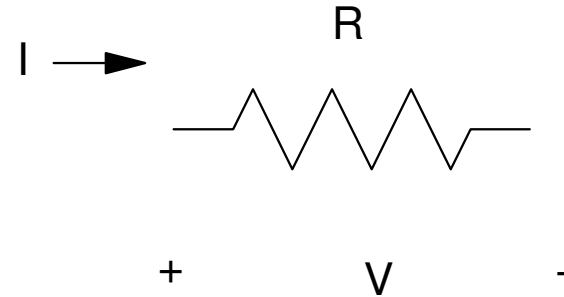

All materials have an innate resistance. For example, copper has a resistivity of

$$\rho = 1.7 \cdot 10^{-8} \Omega m$$

If you have a copper wire that's 100m long and 1mm diameter, it will have a resistance of

$$R = \frac{\rho L}{A} = \frac{(1.7 \cdot 10^{-8} \Omega m)(100m)}{\pi \cdot (0.0005m)^2} = 6.8 \Omega$$

Resistor Color Code

Resistors used in circuits are typically made by winding a long piece of wire around a ceramic core. By varying the thickness of the wire and the length used, you can set the resistance from 0.1 Ohm to 10M Ohms.

Color coding is used to signify the value of a resistor:

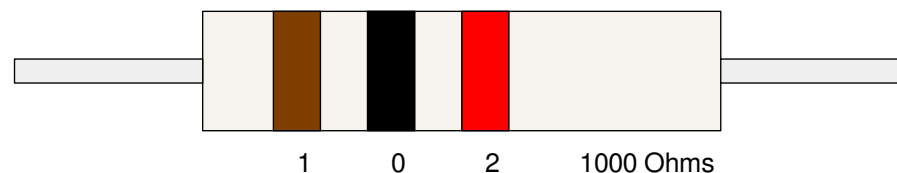

0	1	2	3	4	5	6	7	8	9
black	brown	red	orange	yellow	green	blue	violet	grey	white
Resistance Value									

Silver	Gold	Red	Brown	Green
+/- 10%	+/- 5%	+/- 2%	+/- 1%	+/- 0.5%
Tolerance				

Resistor Values:

Determine the resistance

0	1	2	3	4	5	6	7	8	9
black	brown	red	orange	yellow	green	blue	violet	grey	white

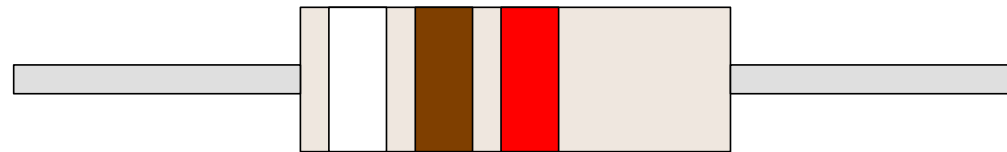
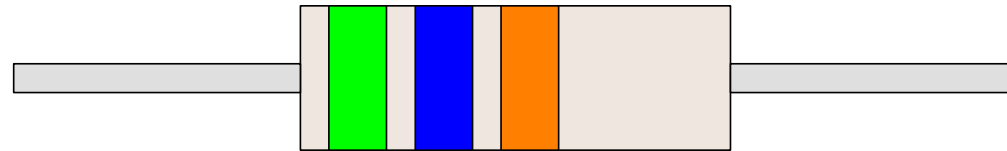
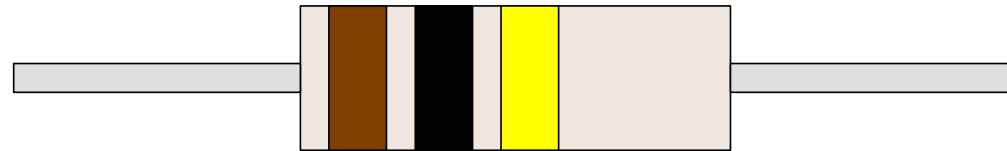

Circuit Analysis: CircuitLab

- When you register, use your NDSU email address
- Otherwise, it's \$24/year to use

Step 1: Drag and drop the circuit elements.

- R rotates the element

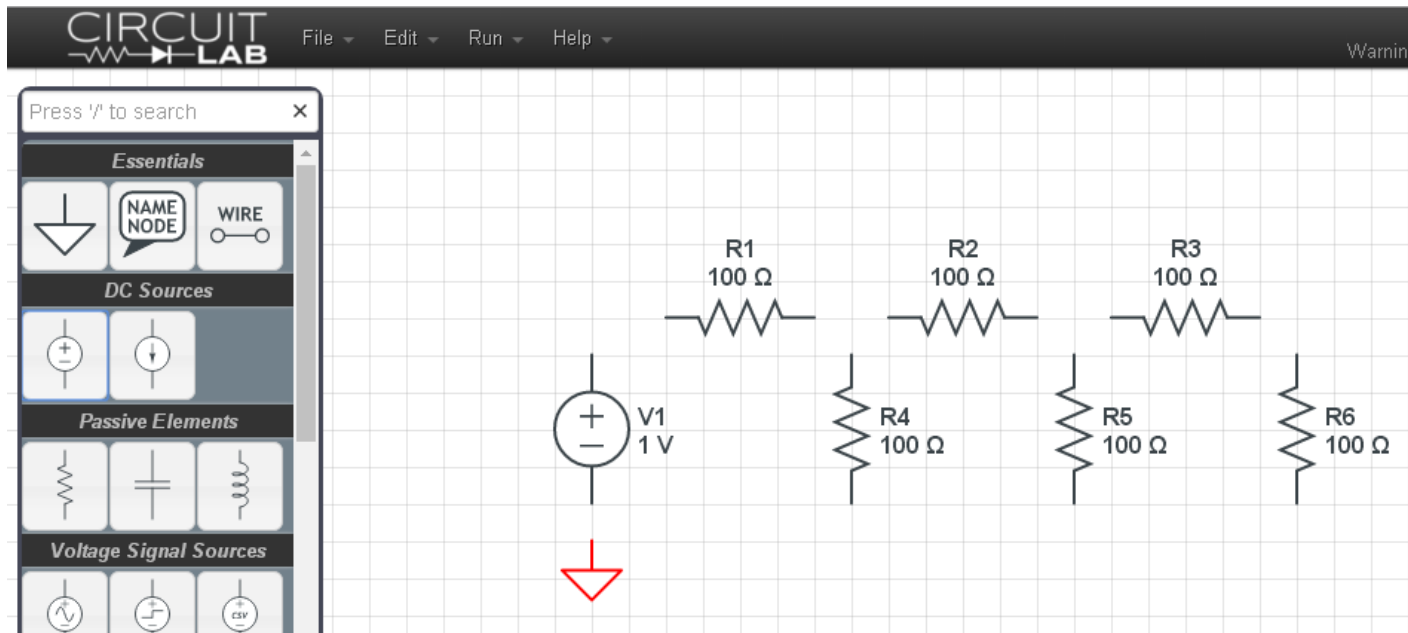

Start of a circuit in CircuitLab

Step 2: Connect the elements together and set the values

- Double click on an element to change it
- Add Node Name for voltages you want to look at

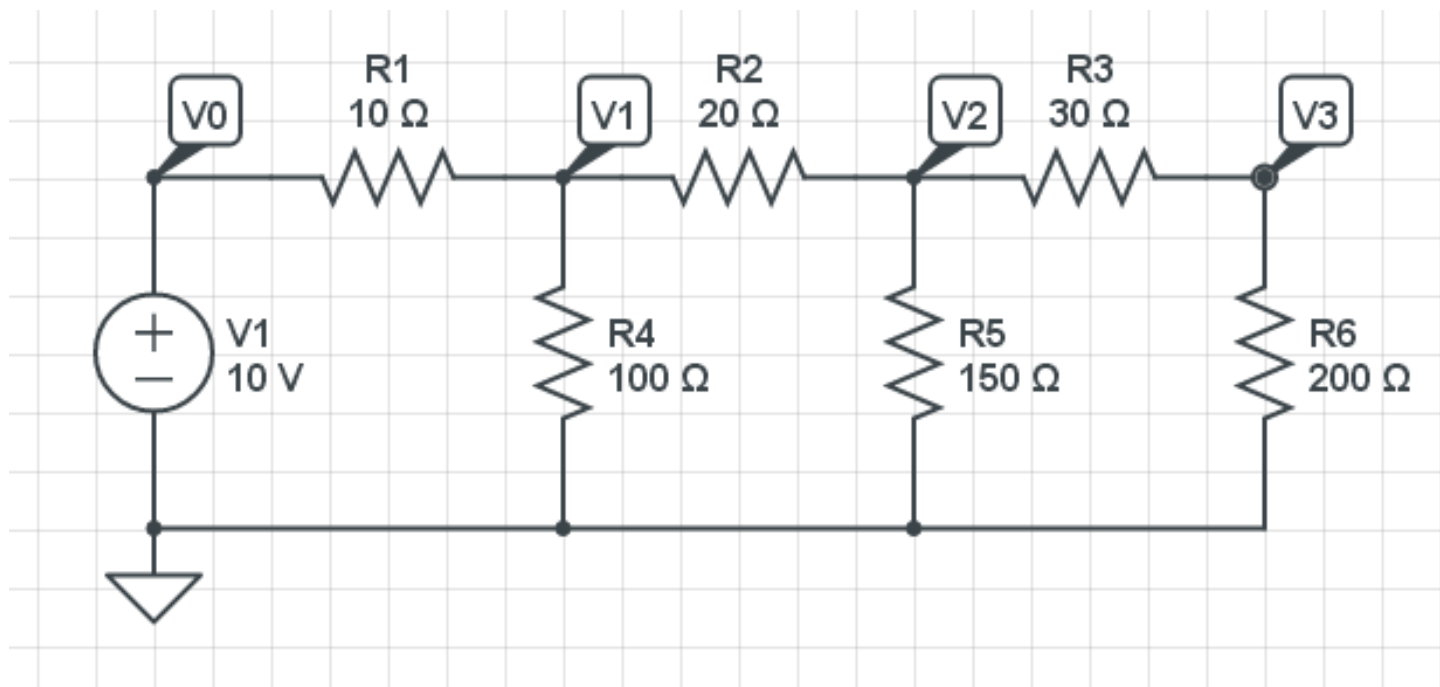

Circuit with elements connected and values set

Step 3: Run a DC simulation

- Simulate
- DC
- + Add Expression (choose V0, V1, V2, V3)
- Run DC Solver

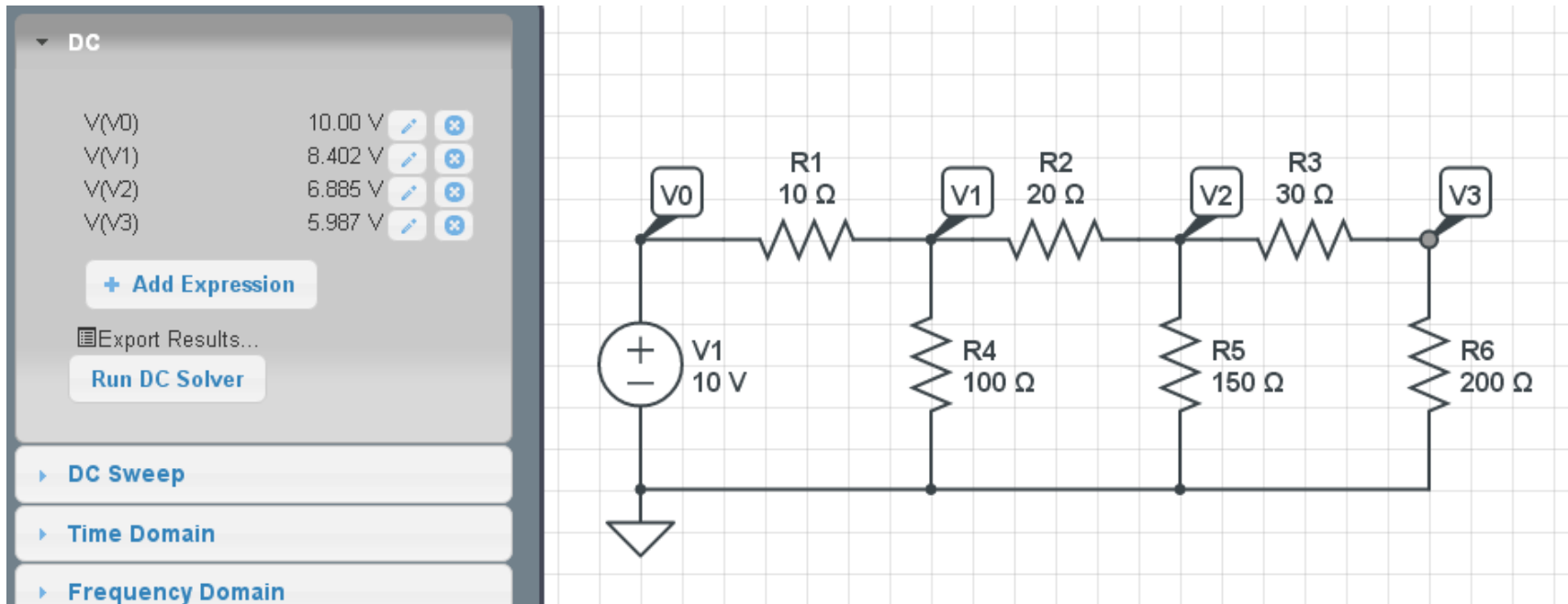

Solving for the voltages in CircuitLab

If you want to know the currents

- Click on the side of the resistor the current goes into (left side of R1, top of R4)
- Run DC Solver

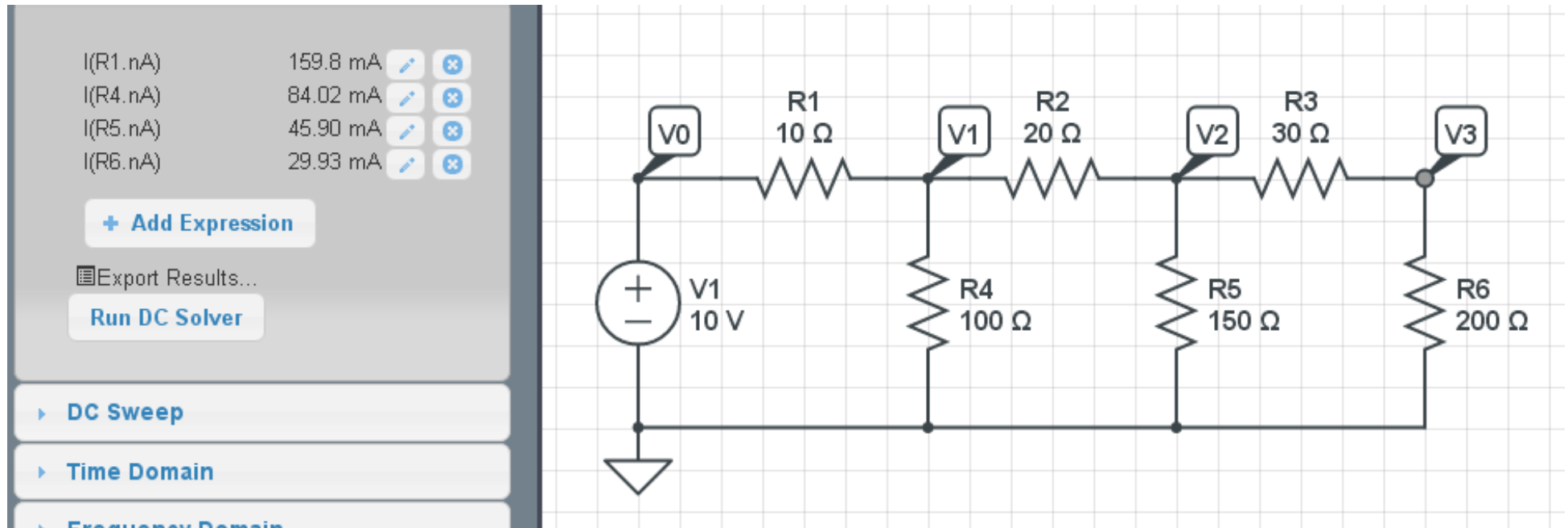

Solving for currents in CircuitLab

Circuit Analysis

Techniques

- Conservation of Voltage: Kirchoff's Voltage Law,
 - Conservation of Current: Kirchoff's Current Law,
 - Simplification of Resistor Circuits, and
 - Voltage Division
-

Voltage Nodes

- Indicated by a solid line.
- All points are the same voltage
- The following circuit has four voltage nodes including ground.

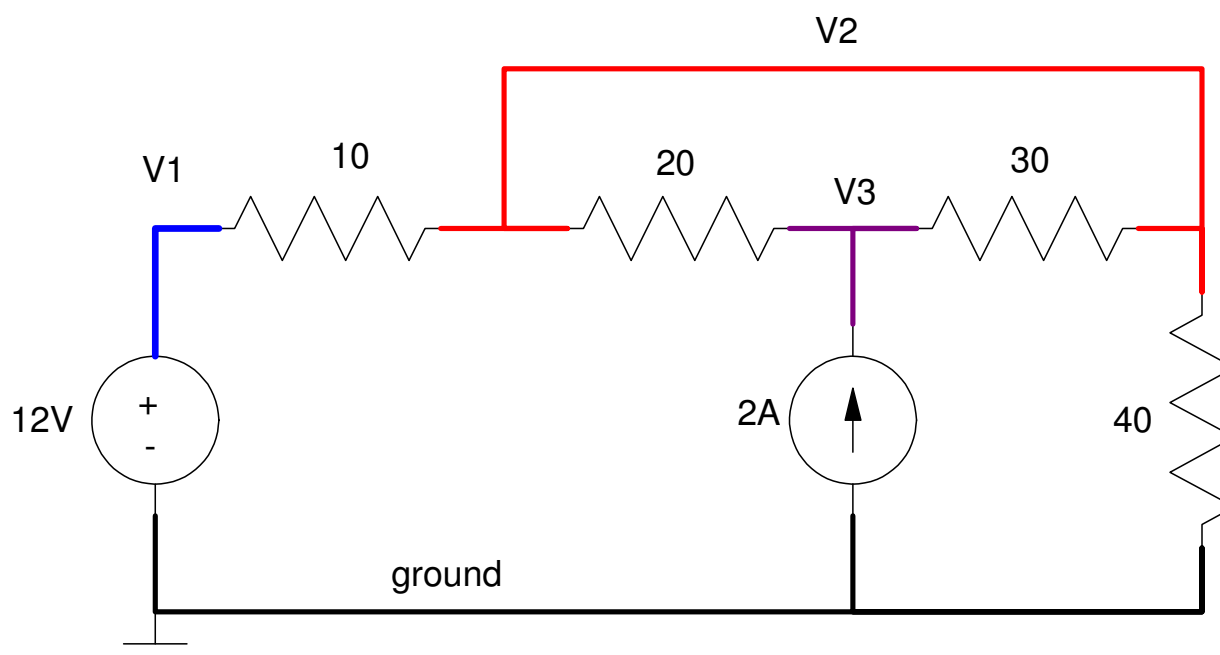

Ground:

- The voltage node which all other voltages are referenced to.
- Usually, ground is the same as earth ground - it doesn't have to be, however.
- Birds sitting on a high-voltage line treat the 13kV line as their ground reference.

Symbols:

- If both appear in a circuit it means two different ground references
- Don't short the two together



Conservation of Voltage: Kirchoff's Voltage Law

The sum of the voltages around any closed path must be zero

- i.e. If you short the leads of a volt meter together, you'll measure 0V.

Example: Determine $V1..V6$

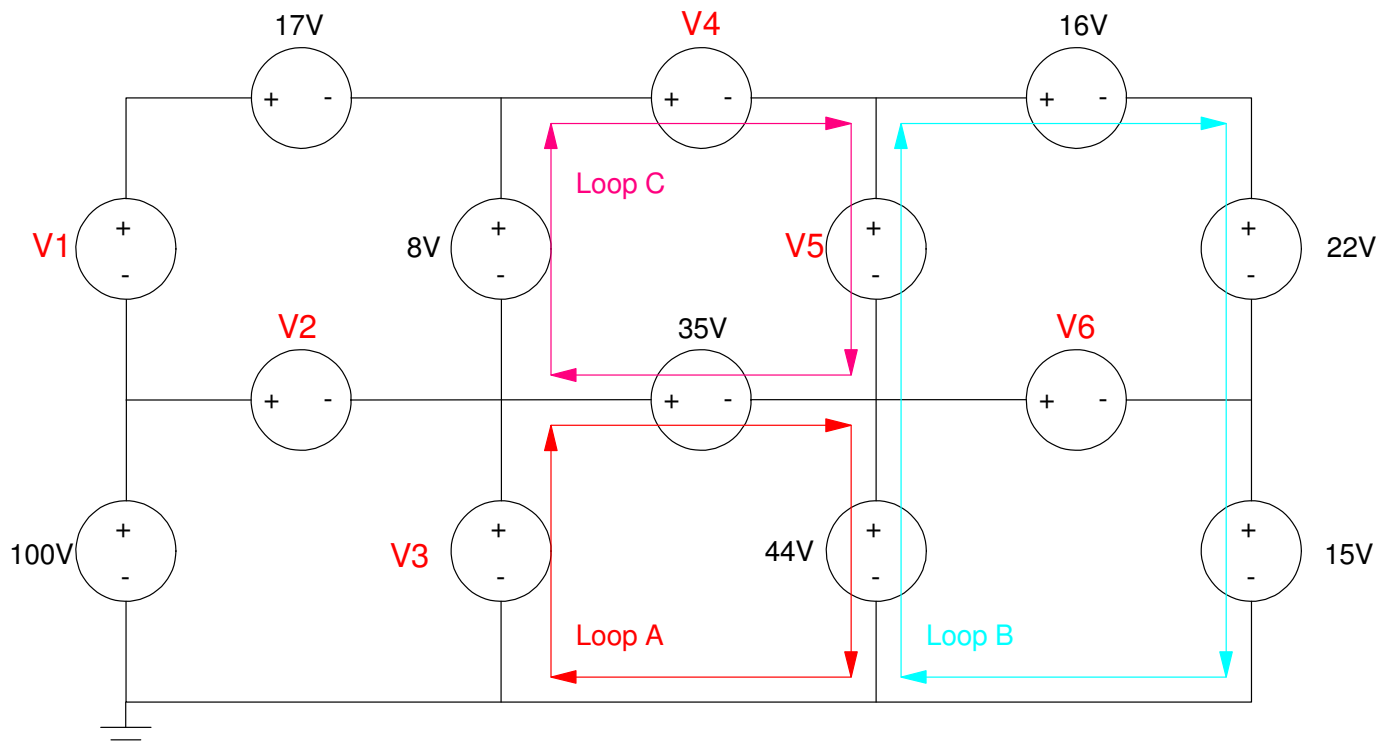

Using Kirchoff's Voltage Law,

- Sum the voltages around a closed path
- To be consistent, add if you hit the + sign first, subtract if you hit the - sign first.
- Look for paths with one unknown.

Loop A:

- $-V_3 + 35 + 44 = 0$
- $V_3 = 79V$

Loop B:

- $-44 - V_5 + 16 + 22 + 15 = 0$
- $V_5 = 9V$

Loop C:

- $-8 + V_4 + V_5 - 35 = 0$
- $-8 + V_4 + 9 - 35 = 0$

$$V_4 = 34V$$

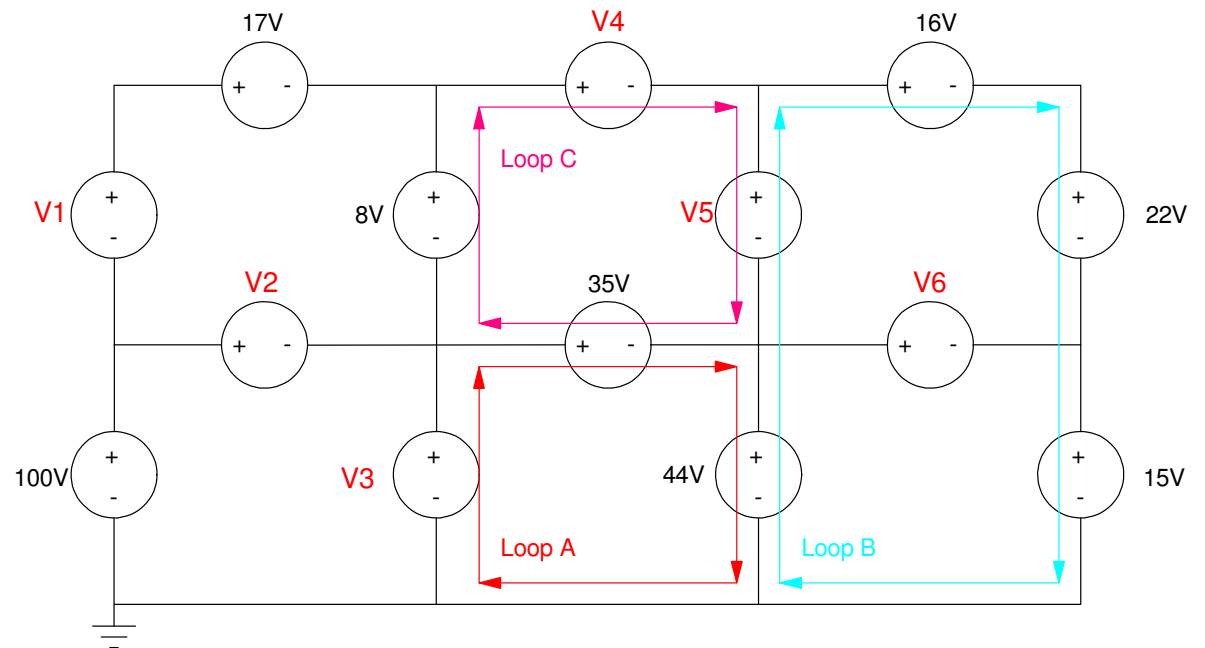

Handout: Determine the unknown voltages

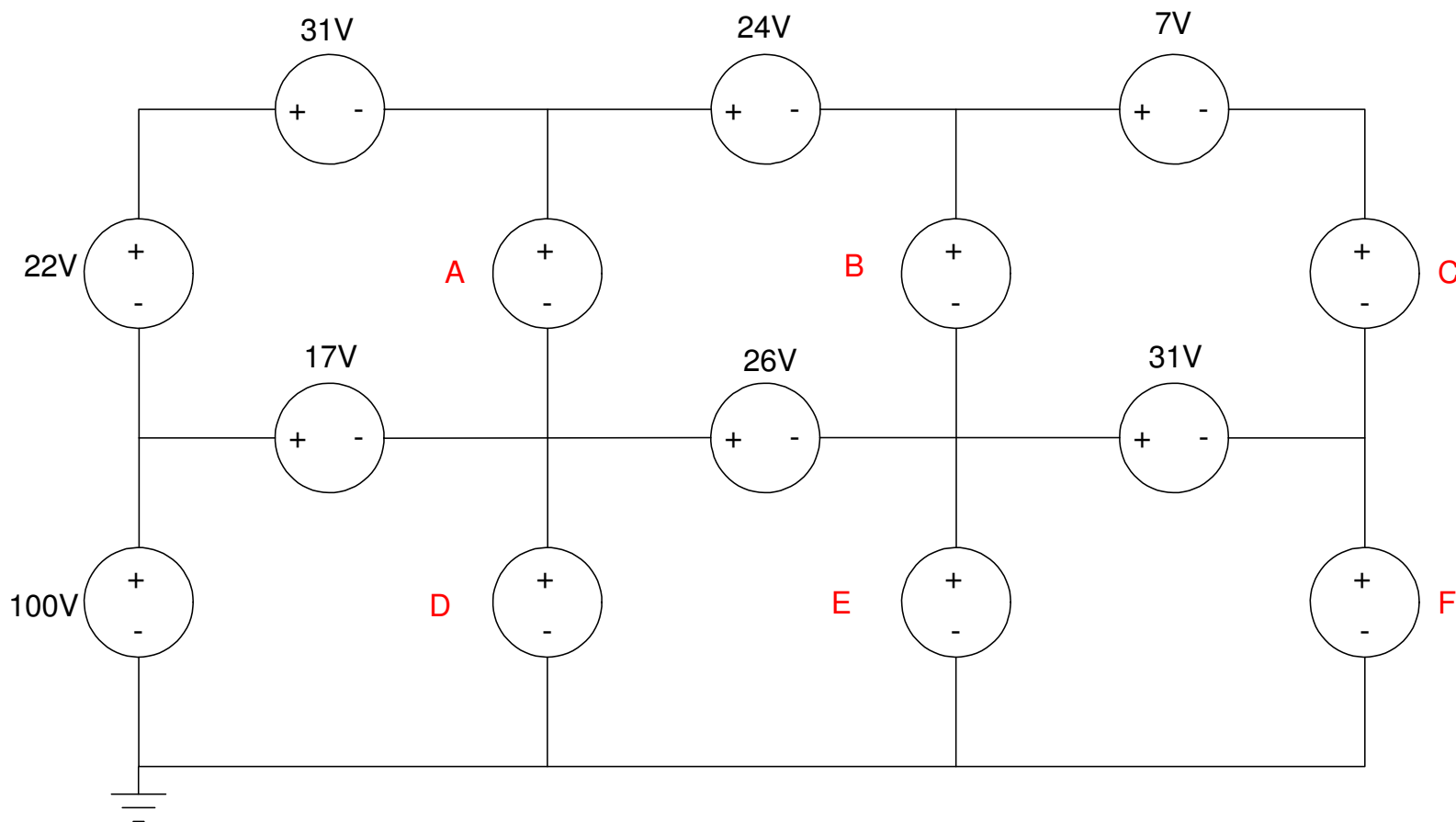

Conservation of Current: Kirchoff's Current Law

The sum of the currents leaving a node must be zero

- The sum of the currents going into a node must be zero
- Current in = Current Out

Kirchoff's current law simply states you cannot create matter.

- Current is the flow of electrons, a physical entity.
 - If you cannot create matter, you cannot create electrons
 - (i.e. current in must match with the current out of a node).
-

Handout: Determine the unknown currents

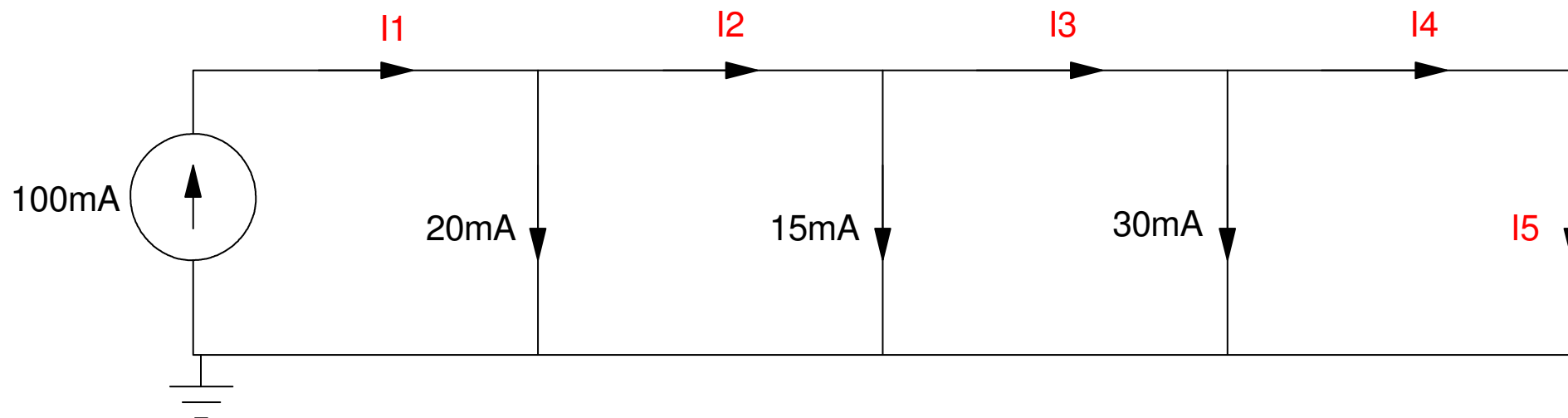

Resistor Circuits

$$V = IR \quad I = \frac{V}{R} \quad R = \frac{V}{I}$$

$$P = VI$$

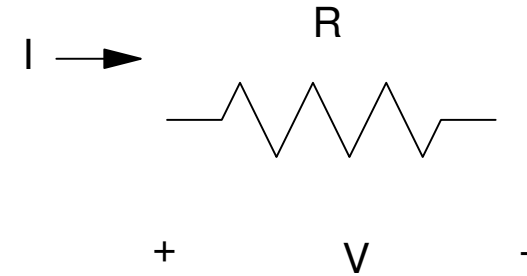

Given two parameters, you can determine the rest

	V (Volts)	I (Amps)	R (Ohms)	P (Watts)
a)	10V	2A		
b)			20 Ohms	5 Watts
c)	10V		5 Ohms	
d)		2A		6 Watts

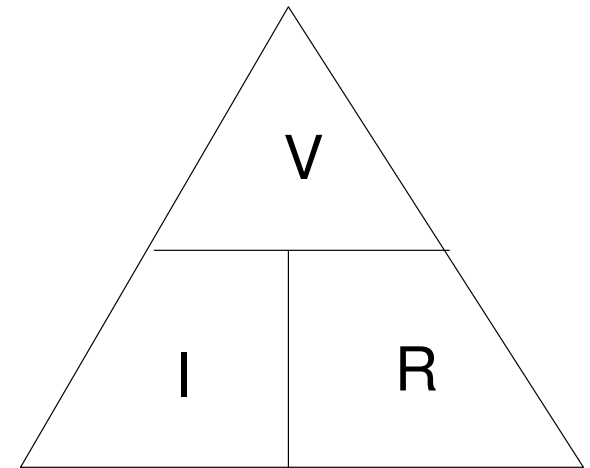

Resistors in Series

- Resistors in series add.

$$V = V_1 + V_2 + V_3$$

From $V = IR$

$$V = IR_1 + IR_2 + IR_3$$

$$V = I(R_1 + R_2 + R_3)$$

The effective resistance is

$$R_{net} = R_1 + R_2 + R_3$$

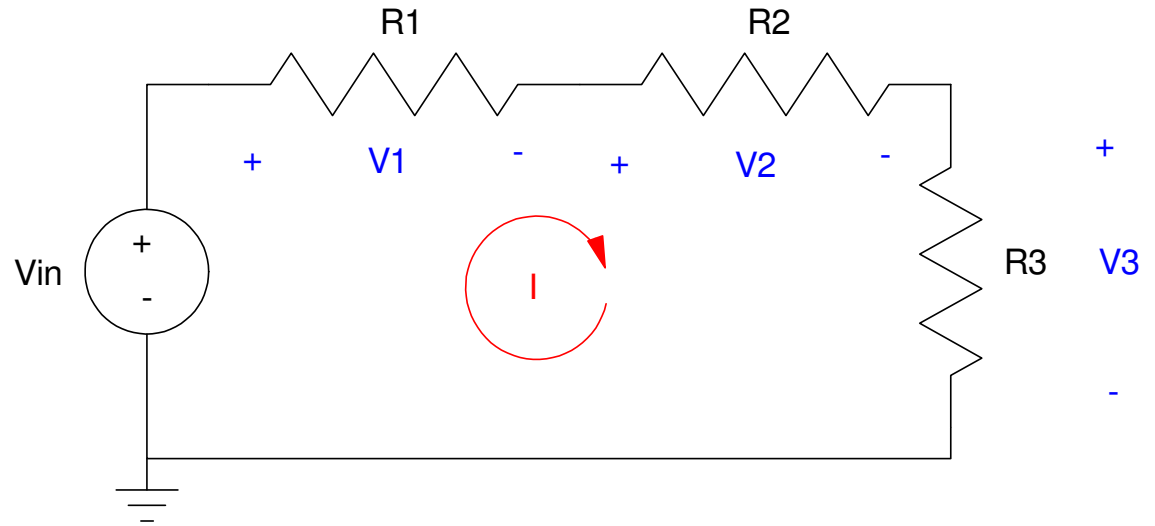

Resistors in Parallel:

These add as the sum of the inverses, inverted.

$$I_a = I_1 + I_2 + I_3$$

From $V = IR$

$$I_a = \left(\frac{V_{in}}{R_1}\right) + \left(\frac{V_{in}}{R_2}\right) + \left(\frac{V_{in}}{R_3}\right)$$

$$I_a = \left(\frac{1}{R_1} + \frac{1}{R_2} + \frac{1}{R_3}\right) V_{in}$$

$$V_{in} = I_a \left(\frac{1}{R_1} + \frac{1}{R_2} + \frac{1}{R_3}\right)^{-1}$$

$$R_{net} = \left(\frac{1}{R_1} + \frac{1}{R_2} + \frac{1}{R_3}\right)^{-1}$$

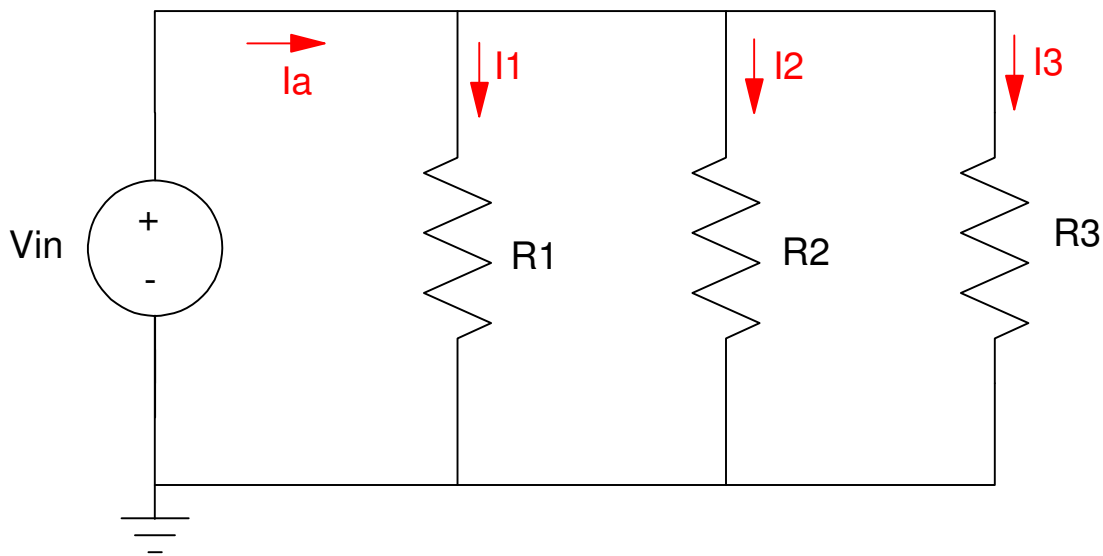

Example 1: Find the resistance from a to b

The 200 and 400 Ohm resistor are in series

$$200 + 400 = 600$$

The 600 (net) and 300 are in parallel

$$300 \parallel 600 = \left(\frac{1}{300} + \frac{1}{600} \right)^{-1} = 200$$

200 (net) and 100 are in series

$$200 + 100 = 300$$

The net resistance is 300 Ohms.

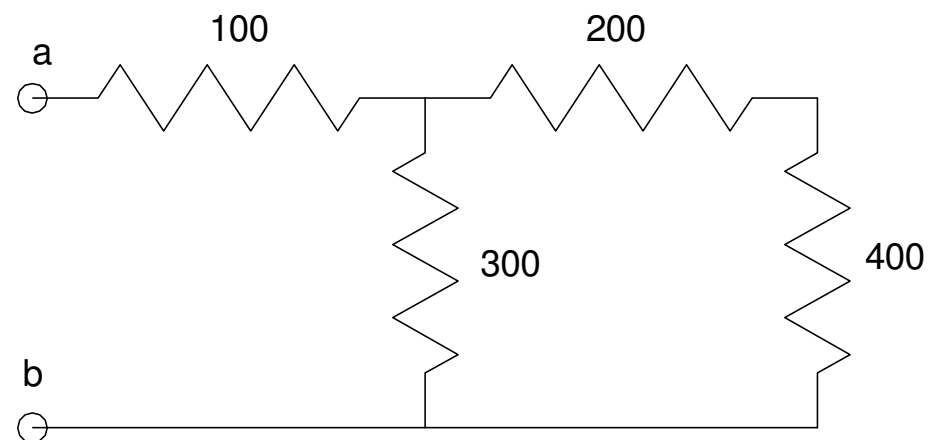

In CircuitLab you can check your answer:

- Build the circuit
- Apply a V test voltage
- Measure the current. From $V = IR$, you should get $1/300A$

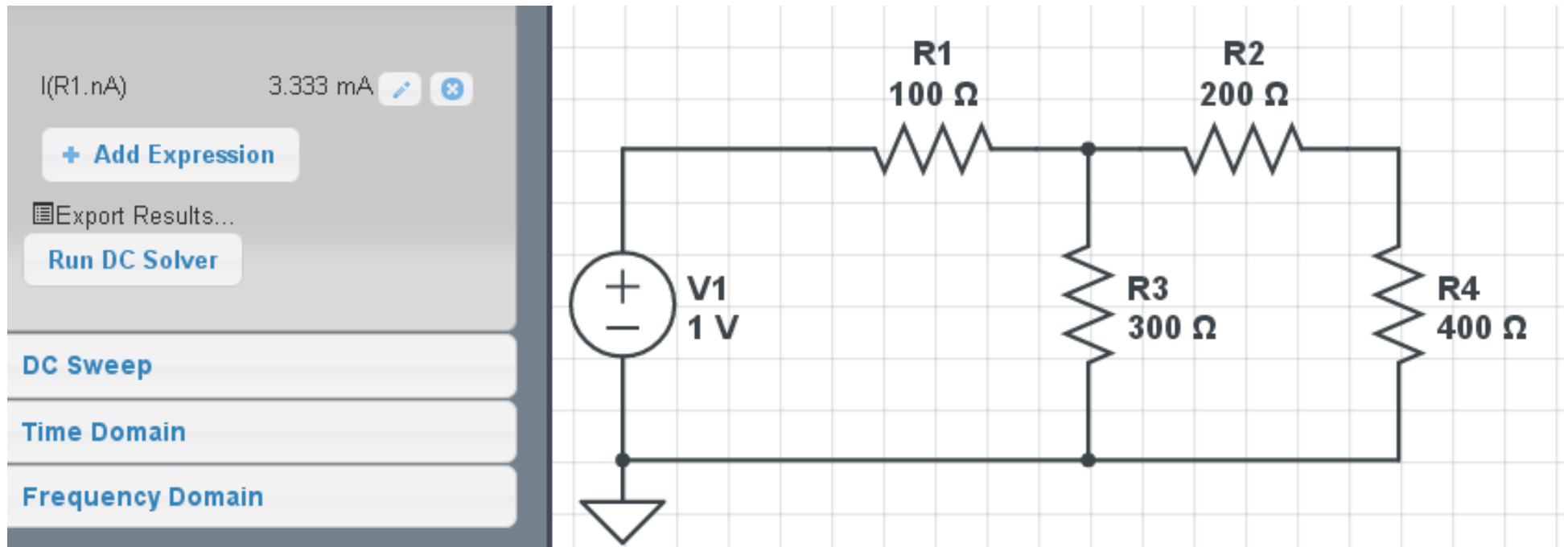

Example 2: Find the net resistance R_{ab}

The 200 and 300 are in parallel

$$200 \parallel 300 = 120 \text{ Ohms}$$

This is in series with 500

$$120 + 500 = 620$$

This is in parallel with 400

$$620 \parallel 400 = 243.137$$

This is in series with 100

$$243.137 + 100 = \mathbf{343.137}$$

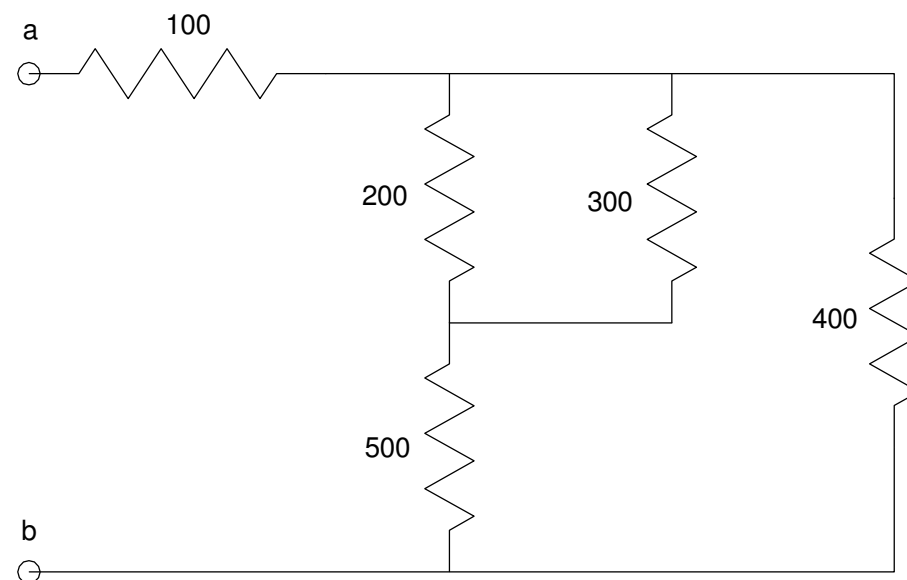

If you apply 1V, you should get 2.914mA ($1 / 343.137$)

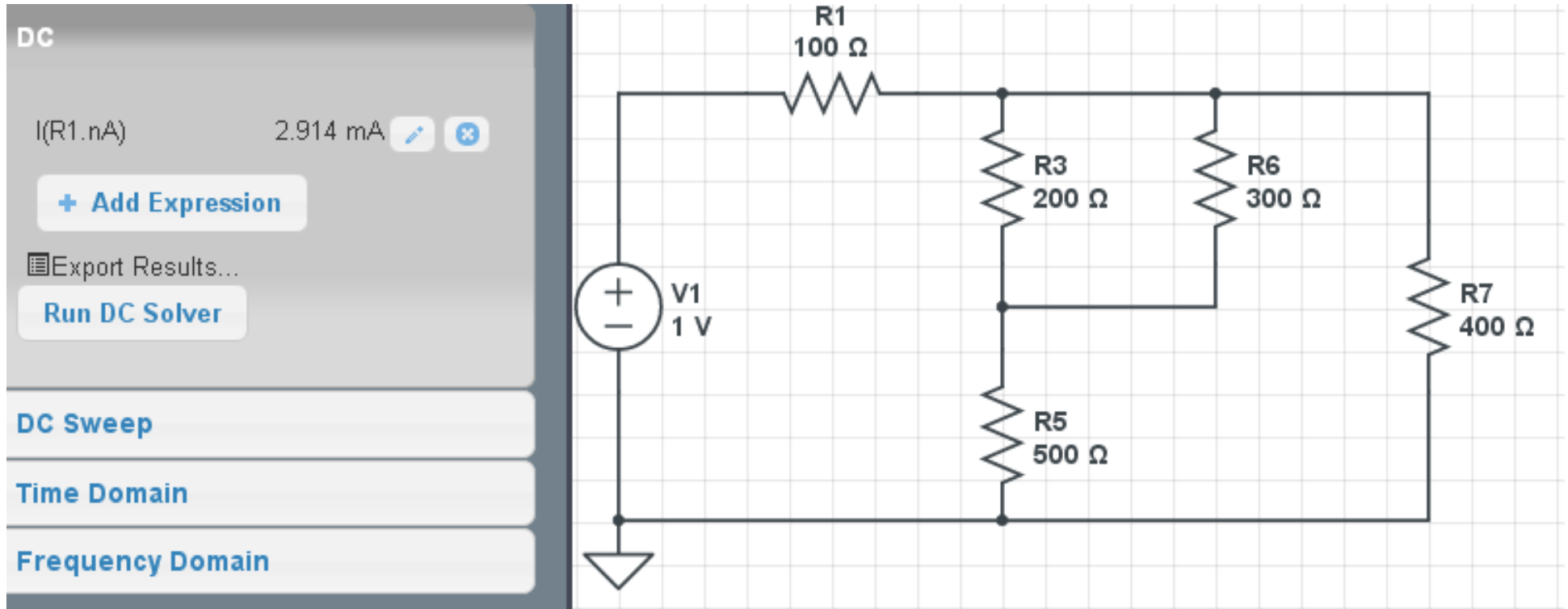

Handout: Determine the resistance from a to b

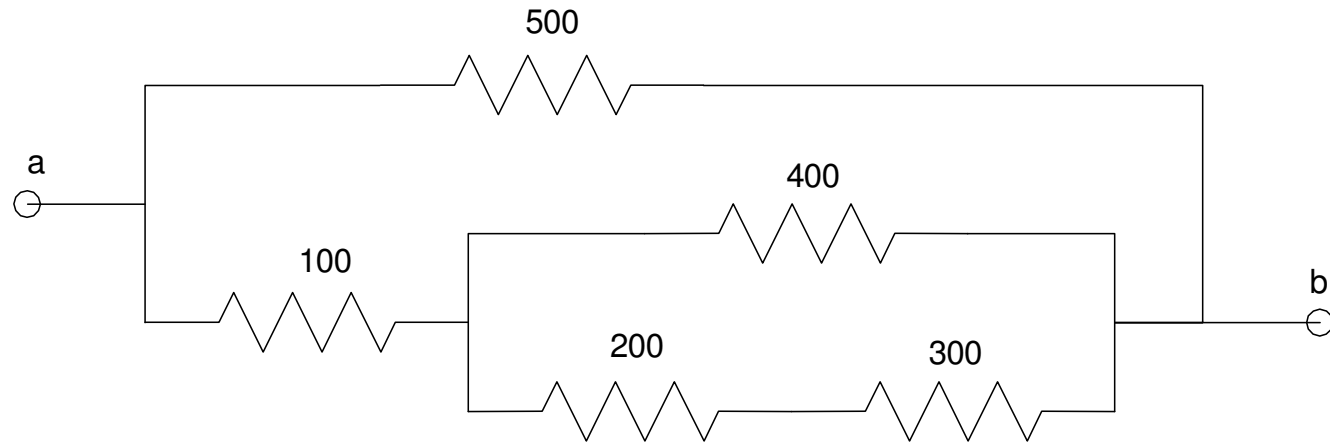

Voltage Division:

The voltage V_3 is

$$I = \left(\frac{V_{in}}{R_1 + R_2 + R_3} \right)$$

$$V_3 = IR_3$$

$$V_3 = \left(\frac{R_3}{R_1 + R_2 + R_3} \right) V_{in}$$

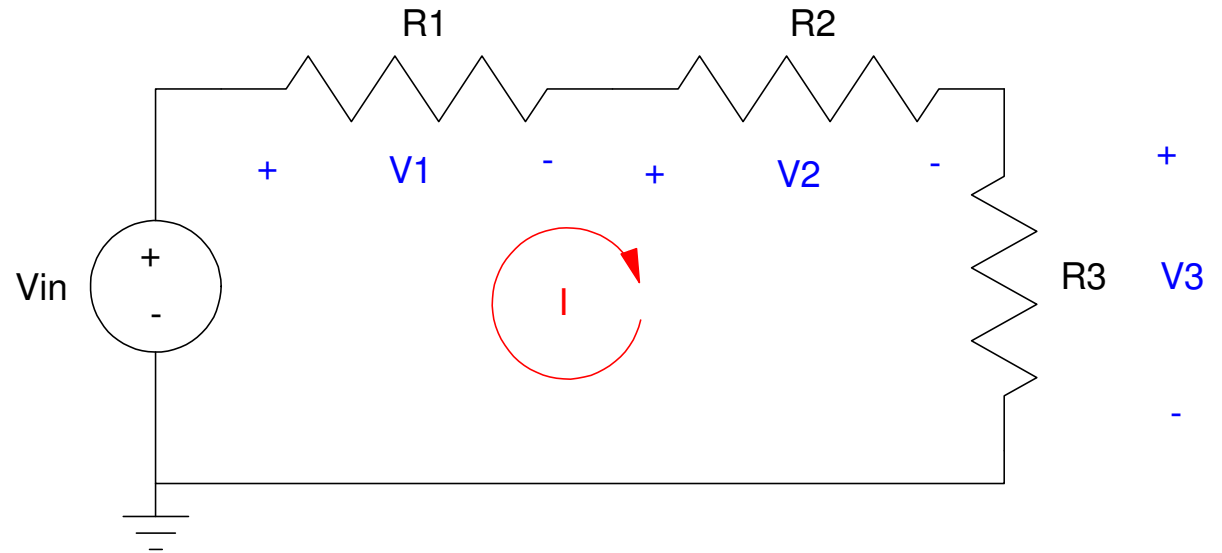

Circuit Analysis with Voltage Division

Find V_1 , V_2 , V_3 via voltage division

$$V_3 = \left(\frac{200}{200+30} \right) V_2$$

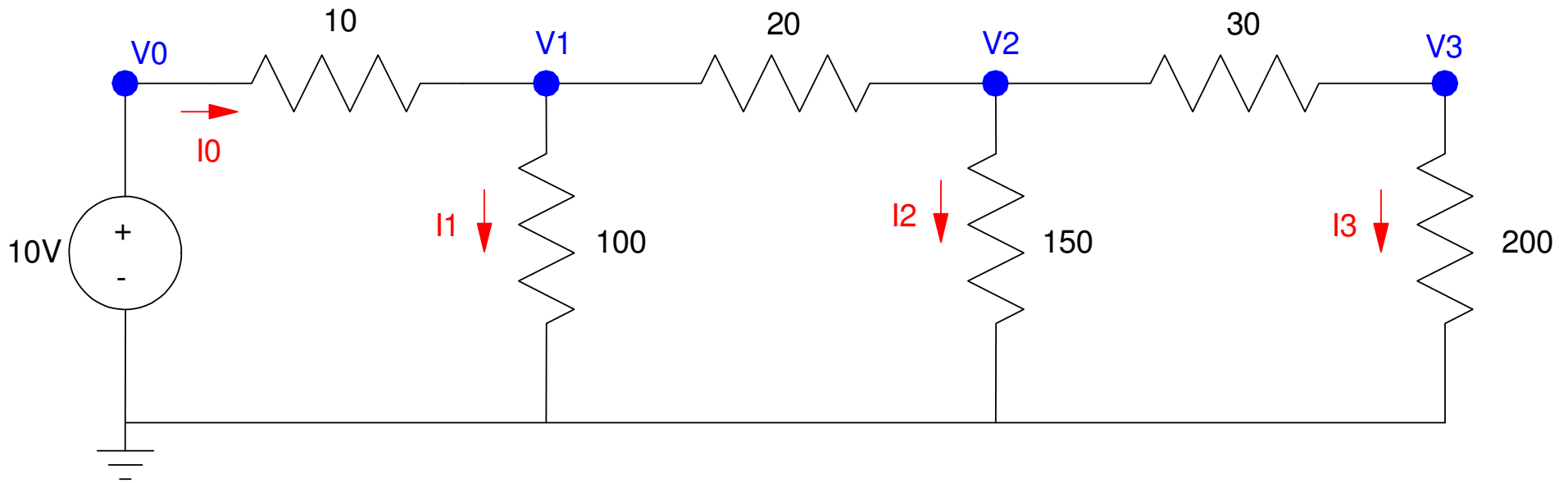

V1: Find the net resistance to ground at V1 looking right

$$200 + 30 = 230 \text{ Ohms}$$

$$230 \parallel 150 = 90.79 \text{ Ohms}$$

$$90.79 + 200 = 110.79 \text{ Ohms}$$

$$110.79 \parallel 100 = 52.56 \text{ Ohms}$$

By voltage division

$$V_1 = \left(\frac{52.56}{52.56+10} \right) 10V$$

$$V_1 = 8.4015V$$

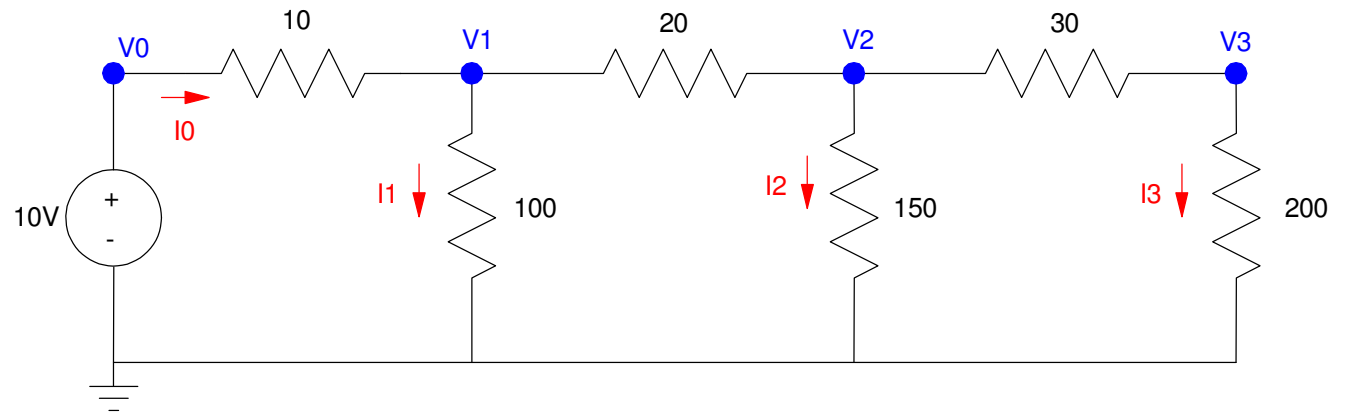

V2 Find the net resistance to ground at V2 looking right

- $V_1 = 8.4015V$

$$200 + 30 = 230 \text{ Ohms}$$

$$230 \parallel 150 = 90.79 \text{ Ohms}$$

so...

$$V_2 = \left(\frac{90.79}{90.79+20} \right) V_1$$

$$V_2 = 6.8849V$$

and

$$V_3 = \left(\frac{200}{200+30} \right) V_2$$

$$V_3 = 5.9868V$$

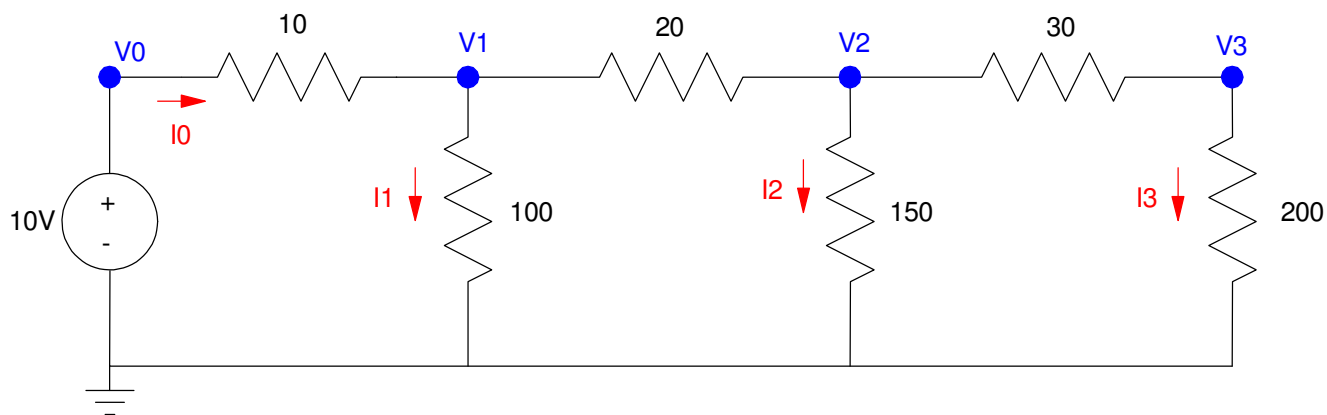

Checking in CircuitLab

- $V1 = 8.4015\text{V}$
- $V2 = 6.8849\text{V}$
- $V3 = 5.9868\text{V}$

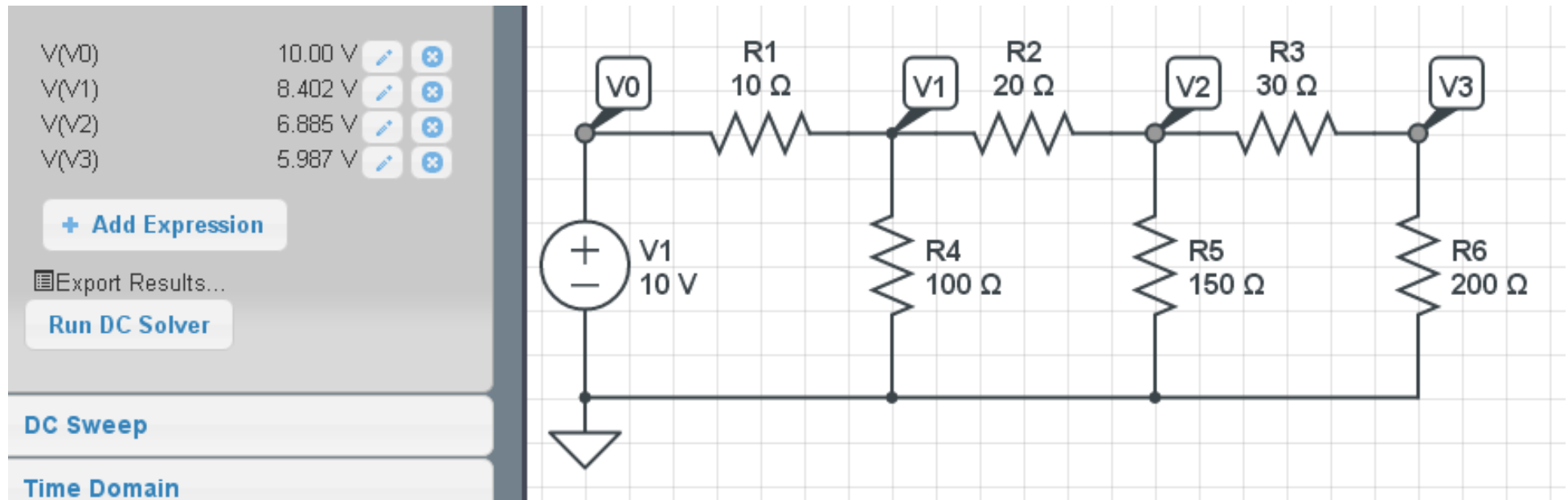

Practice Problem:

Find the voltages using voltage division

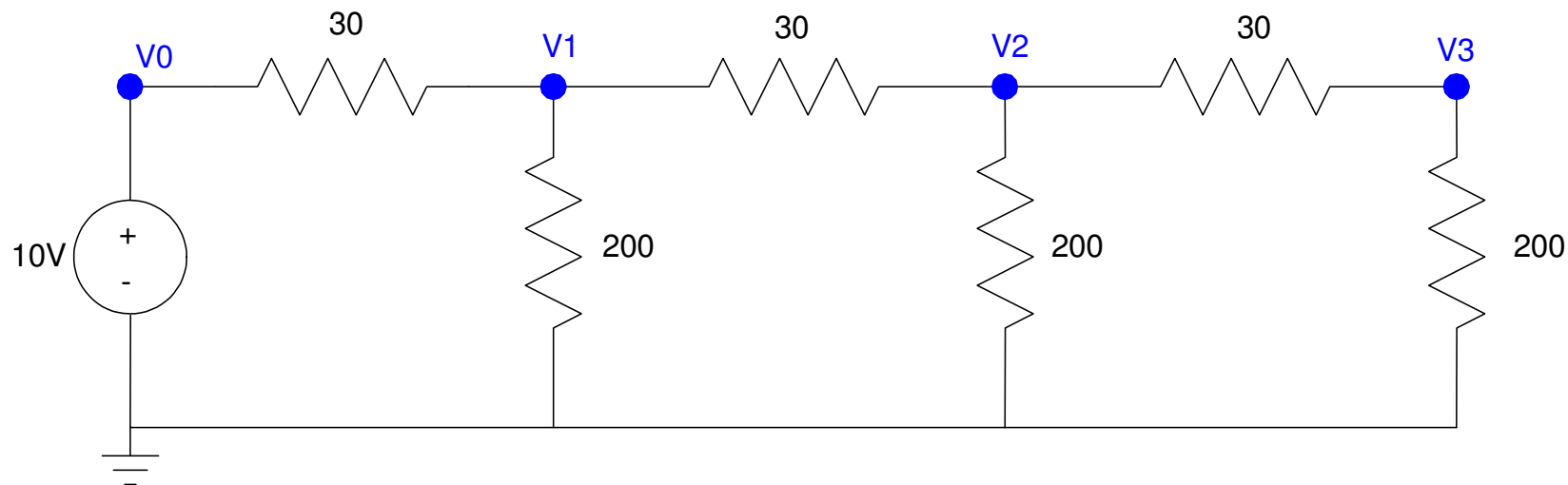

Summary

The basic equations for electrical circuits are

- $V = IR$
- $P = VI$

Resistor circuits can sometimes be simplified

- Resistors in series add
- Resistors in parallel add as $\left(\sum \left(\frac{1}{R_i}\right)\right)^{-1}$

At any node, current in equals current out

- Conservation of current

Around any closed path, the sum of the voltages must add to zero

- Conservation of voltage
-