

ECE 111 - Homework #13

ECE 311 Circuits II - Phasors
Due Monday, November 20th

Phasor Voltages

1) Express V and I as phasors (i.e. as complex numbers)

- From this, determine the impedance, $Z = V/I$

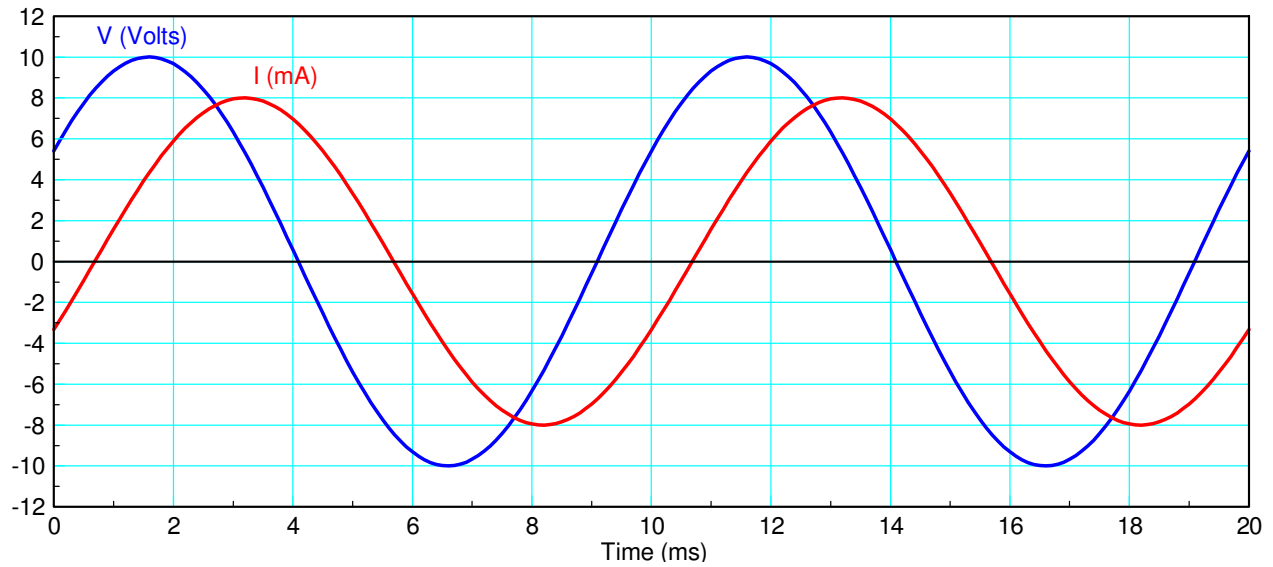

Phasor Impedances

2) Determine the impedance, Z_{ab}

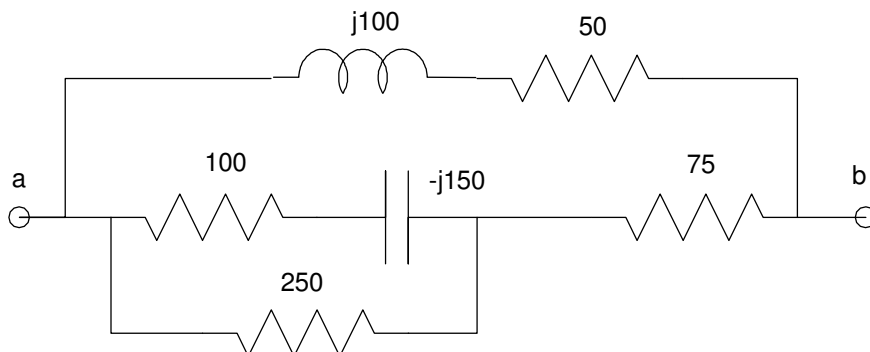

3) Determine the impedance, Z_{ab}

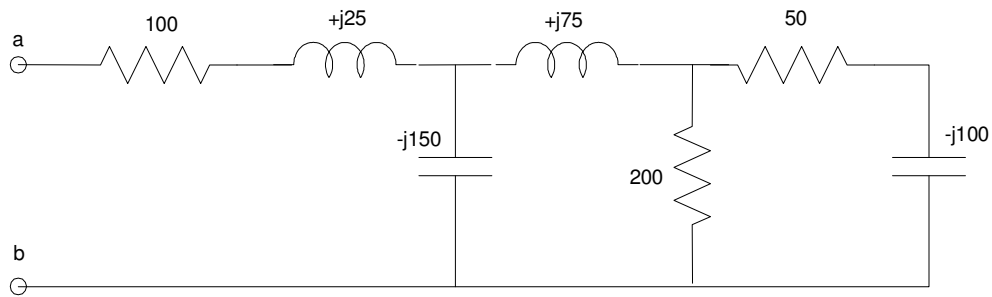

Voltage Nodes with Phasors

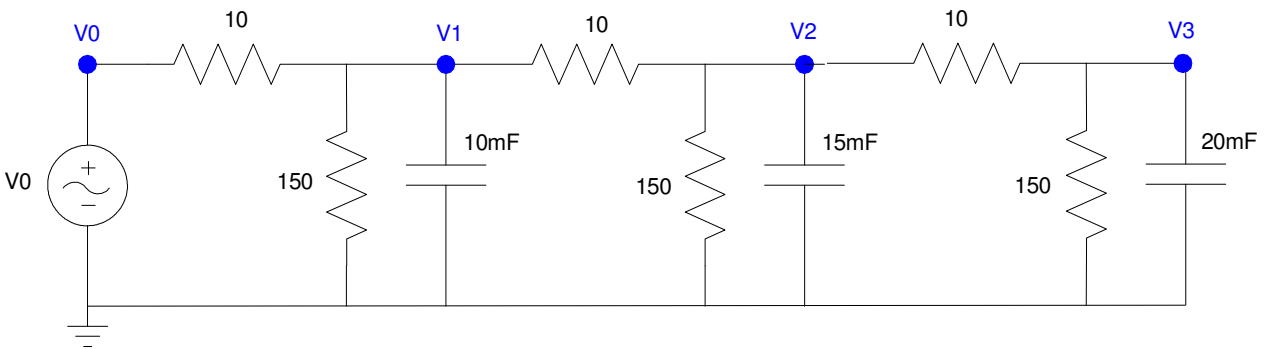

4) Assume $V_0 = 10$.

- a) Determine the impedances of each element at 0 rad/sec
- b) Write the voltage node equations
- c) Solve for V_1 , V_2 , and V_3 .

5) Check your results in CircuitLab

6) Assume $V_0 = 10 \sin(2t)$ *10V, 2 rad/sec sine wave (0.318Hz)*

- a) Determine the impedances of each element at 2 rad/sec
- b) Write the voltage node equations
- c) Solve for V_1 , V_2 , and V_3 as complex numbers
- d) Express V_1 , V_2 , and V_3 in terms of sine and cosine function:
- hint: $V_1 = a + jb$ (phasor representation) means $V_1(t) = a \cos(2t) - b \sin(2t)$

7) Check your results in CircuitLab using a transient simulation for 15 seconds (time step = 15ms).