

ECE 111 - Homework #11

ECE 351 Electromagnetics - Wave Equation
Due Tuesday, November 7th
Please submit BlackBoard

1) Assume the current flowing through a one Henry inductor is shown below. Sketch the voltage.

$$V = L \frac{dI}{dt}$$

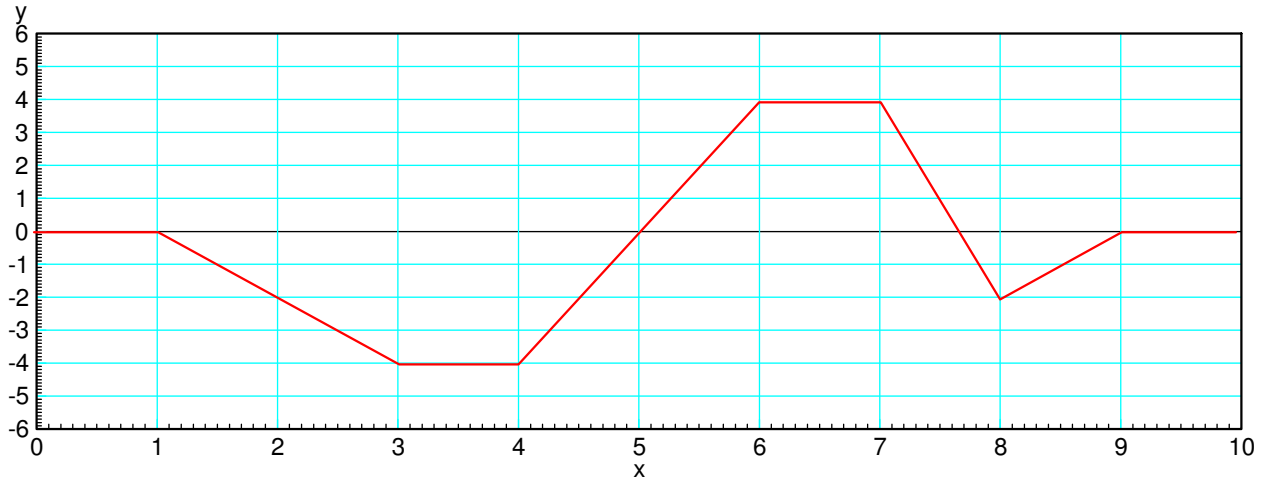

4-Node RLC Circuit

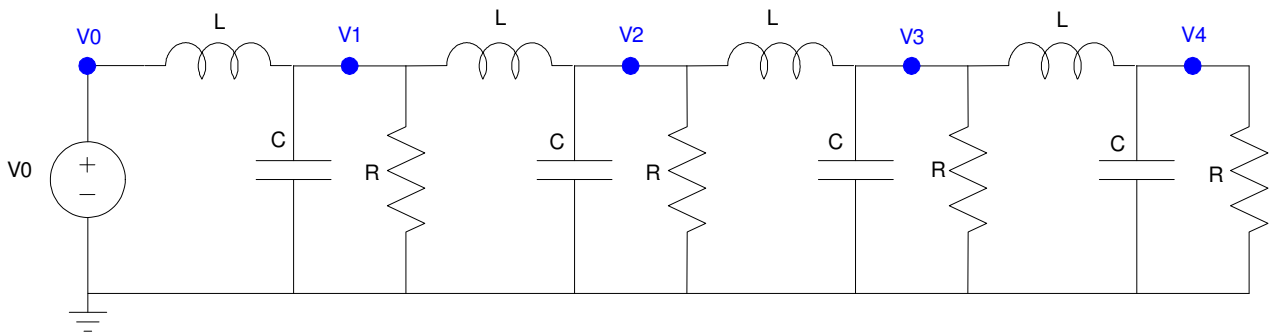

$R = 300\Omega$, $C = 0.2F$, $L = 0.2H$. Repeat for 30 nodes for problems 4-6

2) Write the dynamic equations for the following 4-stage RLC circuit. (i.e. write the node equations)

3) Assume $V_{in} = 10V$ and the initial conditions are zero ($V_1 = V_2 = V_3 = V_4 = 0$). Solve for the voltages at $t = 3$ seconds. *Hint: Solve numerically using Matlab*

30-Node RLC Circuit (hint: modify the program Wave.m)

4) Expand the RLC circuit from problem #2 to 30 nodes. Plot the voltage at $t = 12$ seconds (just after the reflection) for $1 / R_{30}C = 0.01$

5) Plot the voltage at $t = 8$ seconds for $1 / R_{30}C = 100$

6) Determine experimentally R_{30} so that the reflection is almost zero

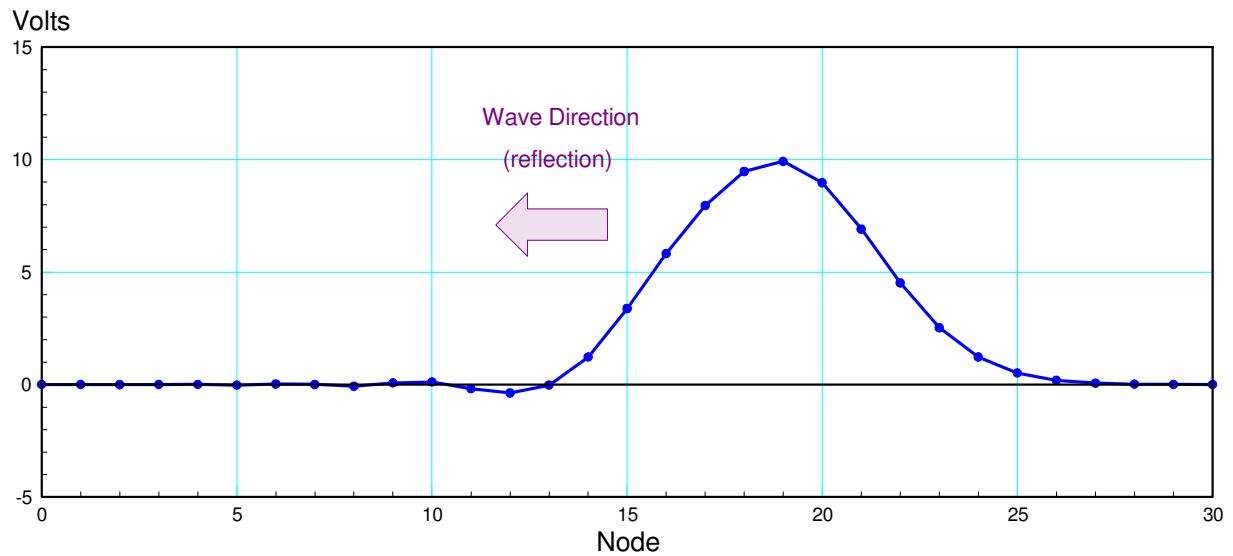

Simulation stopped just after the wave hits the right side and reflects